

Automotive Body Repair and Paint Work Level –III

Based On October 2023, Curriculum Version 1

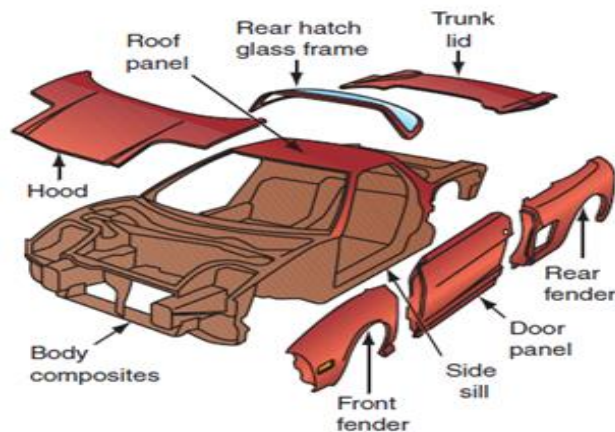

Module Title: Repairing Vehicle Body Panels and Components

Module Code: EIS BRP3M03 1023

Nominal Duration: 70 Hours

Prepared by: Ministry of Labor and Skill

October, 2023

Addis Ababa, Ethiopia

Table of Contents

Acknowledgment	3
Acronym	4
Introduction to Module.....	5
Unit one: - Fundamental of vehicle Body Panels	6
1.1. Basic components of vehicle body panels	7
1.2. Construction of vehicle body Panels.....	10
1.3. Vehicle Body tools and Equipment’s	12
1.4. OHS requirement	22
1.4.1. Shop safety practices and Health Protection	22
Self-check 1.1	25
Unit Two: - Repairing vehicle body panels and components.....	27
2.1. Removing and Tagging body panels and components	28
2.2. Align body panels and components	36
2.3.1. Reinstalling complete panel	45
2.3.2. Reinstalling quarter panel	46
2.3.3. Door panel reinstalling	47
Self-check 2.1	49
Operation Sheet 2.1	51
Operation Sheet 2.2.....	52
Operation Sheet 2.3.....	54
Operation Sheet 2.4.....	55
Operation Sheet 2.5.....	56
Operation Sheet 2.6.....	57
Operation Sheet 2.7.....	58
Unit Tree: - Completing and documenting Work Processes	60
3.1. Final inspection and documentation.....	60
3.2. Checking and storing tools and equipment.....	63
Self-check 3.1	66
LAP Test.....	67
Reference	68

Acknowledgment

The Ministry of Labor and skill wishes to thank and appreciation to MoLS leaders and experts, Regional Labor and skill/training Bureaus leader, experts, TVT College Deans, Instructors and industry experts who contribute their time and professional experience to the development of this Training Module.

Acronym

LAP

OHS

4	Ministry of Labor and Skills Author/Copyright	Automotive Body Repair and Paint Work	Version -III
			October, 2023

Introduction to Module

In order to replace or repair damaged sections of an auto body panel , the technician must begin with a thorough understanding of how the vehicle is constructed. Without a clear understanding of the basics of vehicle construction and assembly, it would be very difficult to follow correct repair procedures. Work improperly done, because of a lack of knowledge about vehicle construction, may result in unsafe conditions which endanger the lives of drivers and their passengers.

This module covers the knowledge, skills and attitudes required to remove, repair, and reinstall body panels and components by hammer and dolly, washer welder, and shrinking method.

This module covers the units:

- fundamental of vehicle Body Panels
- Repair vehicle body panels and components
- Completing and documenting Work Processes

Learning Objective of the Module

- Understand the fundamental of vehicle Body Panels
- Perform Repairing vehicle body panels and components
- Apply Completing and documenting Work Processes

Module Instruction

For effective use this modules trainees are expected to follow the following module instruction:

1. Read the information written in each unit
2. Accomplish the Self-checks at the end of each unit
3. Perform Operation Sheets which were provided at the end of units
4. Do the “LAP test” giver at the end of each unit and
5. Read the identify reference book for Examples and exercise

5	Ministry of Labor and Skills Author/Copyright	Automotive Body Repair and Paint Work	Version -III
			October, 2023

Unit one: - Fundamental of vehicle Body Panels

This unit is developed to provide you the necessary information regarding the following content coverage and topics:

- Basic components of vehicle body panels
- Construction of vehicle body Panels
- Vehicle Body tools and Equipment's
- OHS requirement

This unit will also assist you to attain the learning outcomes stated in the cover page. Specifically, upon completion of this learning guide, you will be able to:

- Understand the Basic components
- Identify Construction of vehicle body panels
- Identify Body tools and Equipment's
- Apply OHS requirement

6	Ministry of Labor and Skills Author/Copyright	Automotive Body Repair and Paint Work	Version -III
			October, 2023

1.1. Basic components of vehicle body panels

Vehicle body – is most expensive part of a car. Vehicle body could be the main supporting structure or its particular element. It is the main supporting structure of a vehicle, to which all other components are attached. Truck uses a separate frame as chassis.

Body shapes

There are six basic body shapes in use: -

1. **Sedan.** A vehicle with front and back seats that accommodates four to six is classified as either a two- or four- door sedan (the vehicle construction is shown in the top left of the figure)
2. **Hard top.** The body structure is almost the same with sedan shape but it lacks door pillars that extend to the roof.
3. **Convertible top.** Today's convertible top vehicle has a vinyl or cloth roof that can be raised or lowered. Like a hardtop, a convertible top has no door pillars and, depending on the make, can be purchased with or without a back window.
4. **Lift back /hatch back.** The distinguishing feature of this vehicle is its rear luggage compartment, which is an extension of the passenger compartment. The vehicle comes in three- and five- door models.
5. **Station wagon.** A station wagon is characterized by its roof, which extends straight back for the length of the vehicle, allowing a spacious interior luggage compartment in the rear.
6. **Sports /multipurpose vehicles.** This new classification of vehicles covers a range of body designs. They are available in two-wheel drive, four-wheel drive, or all-wheel drive.

7	Ministry of Labor and Skills Author/Copyright	Automotive Body Repair and Paint Work	Version -III
			October, 2023

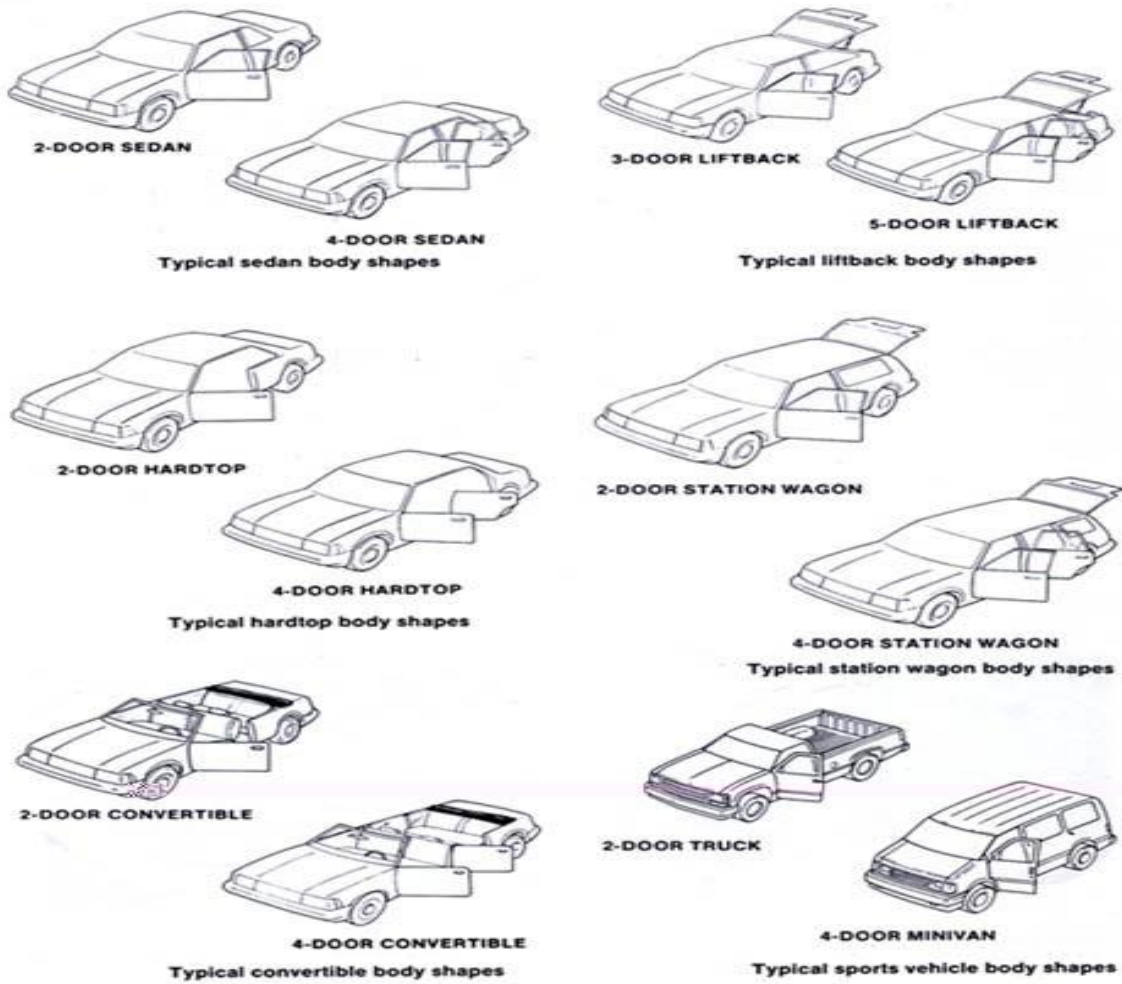

Figure1. Six basic body shapes

Components of vehicle body panels

- front fender
- front and rear door
- hood
- trunk lid
- back door
- tail gate
- roof

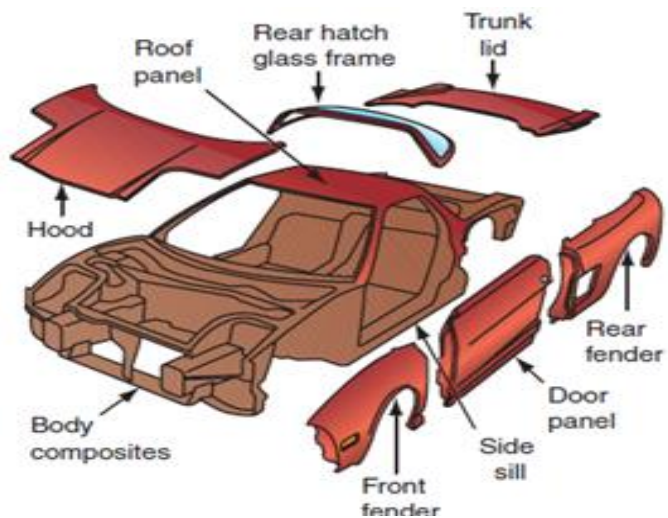

Figure1- 1 Components of vehicle body panels

8	Ministry of Labor and Skills Author/Copyright	Automotive Body Repair and Paint Work	Version -III
			October, 2023

Front fender

The fender is the curved part of the car's body that sits on top of the wheels and holds them in place. It is not only a safety component but also enhances the overall look of your vehicle. Its primary function is to shield and protect the passenger compartments by preventing sand, mud, rocks, liquids, and other roads spray from being thrown into the air by the rotating tire.

A car tire fender is a plastic, metal, or rubber panel that bends over the wheel on the side of the car, extending from the front bumper to the car door.

Front and rear door

The door allows entering and exiting the vehicle. The doors can be opened manually, or electrically powered. A conventional car door is hinged at its front-facing edge, allowing the door to swing outward from the car body. This type of door has the advantage that if it is opened during forward motion of the vehicle, the wind resistance will work against the opening door, and will effectively force its closure.

Hood

The hood protects the engine from debris and other hazards, including direct sunlight and rain.

Trunk lid

The trunk lid is the cover that allows access to the main storage or luggage compartment. Hinges allow the lid to be raised. Devices such as a manually positioned prop rod can keep the panel up in the open position. Counterbalancing torsion or other spring(s) can also be used to help elevate and hold open the trunk lid.

Tail gate

Tail-gate simply refers to the back of the car that can open and close. An automatic tail-gate in the car will do the process of shutting and opening the tail-gate electronically.

Roof

An automobile roof or car top is the portion of an automobile that sits above the passenger compartment, protecting the vehicle occupants from sun, wind, rain, and other external elements.

9	Ministry of Labor and Skills Author/Copyright	Automotive Body Repair and Paint Work	Version -III
			October, 2023

1.2. Construction of vehicle body Panels

In today's passenger cars basically there are two methods of construction

- A. Conventional body-over-frame
- B. Unitized or uni-body

A. Conventional body-over-frame construction

The frame (chassis) & body are built as two separate units.

- The body is assembled on to the frame with mounting brackets which have rubber bushed bolts to hold the body to the rigid frame. This means that the car can be dismantled into the two units of body and frame. The body and all major parts of a vehicle are attached to the frame.

Characteristics of conventional body over frame: -

- Load-induced vibrations that are transferred to the body via the frame, thus resulting in a smooth ride.
- Rubber mounting between the body and frame insulate it from vibrations, providing a quiet interior.
- High amount of energy are absorbed during a collision
- Under surfaces of the body are protected over rough roads
- Suspension and power train parts can be quickly assembled on the basic frame
- Heavy frame made of thick sheet metal is approximately 3/64 to 1/8 inch.
- The vehicle profile is generally high of the ground

A. Unitized/ unibody

- This construction employs the same principles of the aircraft
- The main aim is to strengthen the body without unnecessary weight
- It has no separate frame like conventional type
- The egg shell is often cited as an example of this type of body structure
- Even when pressing hard on an egg shell, it is comparatively difficult to destroy since all the strength applied by the fingers is not concentrated in one place but is dispersed effectively through the entire shell (this action is called **stressed ball structure**)

10	Ministry of Labor and Skills Author/Copyright	Automotive Body Repair and Paint Work	Version -III
			October, 2023

- In a car body, there is no complete stressed hall structure.

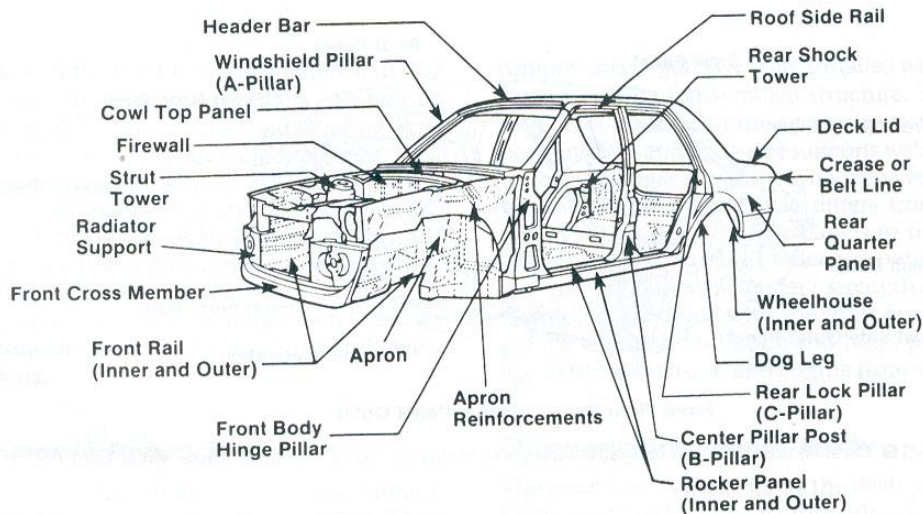

Figure1- 2 Body Constructions

Characteristics of uni-body:-

- It is made by combining pieces of thin sheet metal processed to form panels of various shapes and joined into an integrated structure by spot welding. This light structure is highly rigid to bending or twisting.
- The bulk taken by the frame can be used to make the car more compact
- Vibration and noise from the drive train & suspension enter the floor pan & are amplified by the body, which acts an acoustic chamber making it necessary to add extra components to the body to suppress vibration & noise
- Once deformed, special procedures, which do not cause additional damage, are needed to restore it to its original shape
- With the thin sheet metal body close to the road surface, adequate measure must be to prevent the deterioration in strength from corrosion, This is particularly important when dealing with rein forcing materials that make up the under body.

Types of body panel

There are two types of body panels:

- Outer body panels, which include horizontal panels (hoods, deck lids, and roof) and vertical panels (door and quarter panels) and
- Inner body panels, such as wheelhouse and rear floor

11	Ministry of Labor and Skills Author/Copyright	Automotive Body Repair and Paint Work	Version -III
			October, 2023

1.3. Vehicle Body tools and Equipment's

Body working tools include some very familiar general purpose metal working tools as well as specialized tools only used in auto body repair. The following is a description of the most commonly used body working tools. Because of the wide variety of hammers, files and dollies, some of the less common varieties are not discussed but the tool collection of advanced auto body repair technicians will include all the tools necessary for performing every metal shaping technique, no matter how unusual. A typical set of body working tools is shown in

Body Hammers

Body hammers are the basic tools for pounding sheet metal backs in to shape. They come in many different designs. Some have flat, square heads; some have rounded heads; and some, called picking hammers, have pointed heads. Every style is designed for a special use for which it is ideal.

Picking Hammers



Figure1- 3 Picking Hammers

The picking hammer will take care of many small dents. The pointed end is used to hammer out small dents from the inside; a gentle tap in the centre usually does it. The flat end is for hammer- and-dolly work to remove high spots and ripples. Picking hammers come in a variety of shapes and sizes. Some have long picks for reaching behind body panels. Some have sharp "pencil" points' other have blunted bullet points.

Be careful when using the pick hammer if swung forcefully, the pointed end can pierce the lighter sheet metals used in late model cars. Use the pick only on small dents.

12	Ministry of Labor and Skills Author/Copyright	Automotive Body Repair and Paint Work	Version -III
			October, 2023

Finishing Hammers

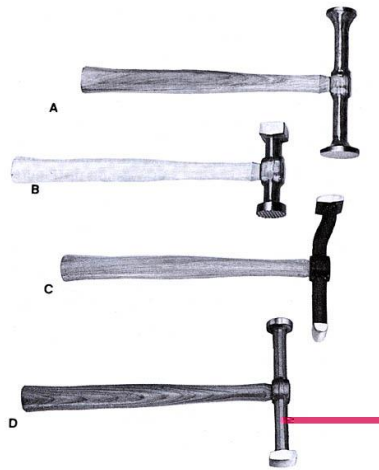

After the bumping hammer is used to remove the dent, final contour is achieved with the finishing

hammer. The faces on a finishing hammer are smaller than those of the heavier bumping hammer. The surface of the face is crowned to concentrate the force on top of the ridge or high spot. A shrinking hammer is a finishing hammer with a serrated or cross-grooved face. This hammer is used to shrink spots that

have been stretched by excessive hammering.

Figure1- 4 (A) Double round hammer (B)&(E) Shrinking hammer (C) Off-set bumping hammer (D) Dinging hammer



DOLLIES



The dolly or dolly block is used like an anvil. It is generally held on the backside of a panel being struck with a hammer. Together the hammer and dolly work high spots down and low spots up

There are many different shapes of dollies each shape is intended for specific types of dents and body panel contours-high crowns

Figure1- 5 (A) Double round hammer (B)&(E) Shrinking hammer (C) Off-set bumping hammer (D) Dinging hammer

13	Ministry of Labor and Skills Author/Copyright	Automotive Body Repair and Paint Work	Version -III
			October, 2023

low crowns, flanges, and others. It is very important that the dolly fits the contour of the panel. If a flat dolly or one with a low crown is used on a high crown panel, additional dents will be the result.

A general-purpose dolly has many contours. It can be used most situations. A rail type dolly is another commonly used dolly with money contours toe and heel dollies are used for bumping in tight places, and the flat right angle edge is used for straightening flanges.

Spoon

Body spoons are another class of body working tools that are used sometimes like a hammer and sometimes like a dolly. Available in a various of shapes and sizes to match various panel shapes, the flat surface of a spoon distribute the striking over a wide area..

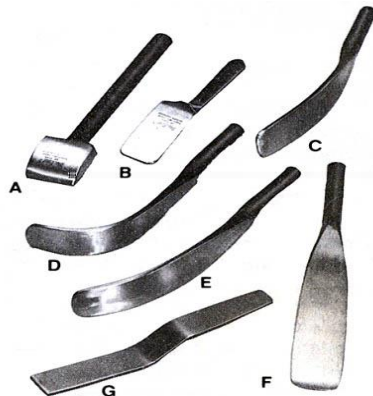

They are particularly useful on crease and ridges. A spoon dolly can be used as a dolly where the space behind a panel is limited. A dinging spoon is used with a hammer to work down ridges. Inside spoons can be used to pry up low places or can be struck with a hammer to drive up dents. Bumping files have serrated surfaces and are used to slap ridges or the underside of creases to bump the metal back to its original shape.

Figure1- 6 A)spoon dolly B)light dinging spoon C)surfacing spoon D)Inside high crown E)Inside medium crown F)inside heavy-duty spoon G)bumping file

Lowering a ridge with a hammer and spoon

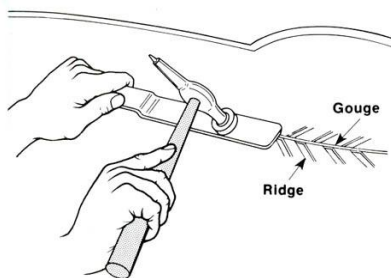

Serrated surface and are used to slap ridges or the underside of creases to hump the metal to its original shape.

14	Ministry of Labor and Skills Author/Copyright	Automotive Body Repair and Paint Work	Version -III
			October, 2023

Picks

Picks like spoons, are used to reach in to confined spaces. The pick is used only to pry up low spots. They vary in length and shape and most have a U- shaped end that serves as a handle. Picks are commonly used to rise low spots in door, quarter panels, and other sealed body sections. Picks are often preferred to slide hammers and pull rods because they do not require drilling holes in the sheet metal.

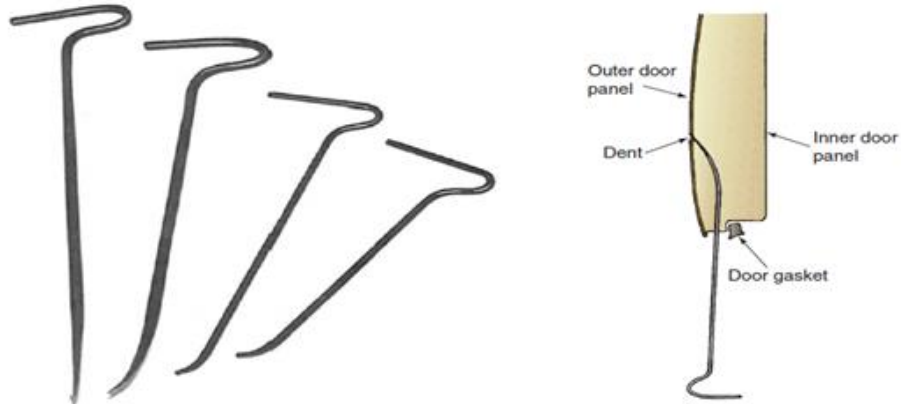

Figure1- 7 picks

Dent pullers and pull rods

Creases in sealed body panels or panel sections that can not be reached from backside even with the longest spoon can be pulled out with a dent puller or pull rod. Either tool requires one or more holes drilled or punched in the crease.

A dent puller usually comes with a threaded tip and hook tip. Either tip is inserted in the

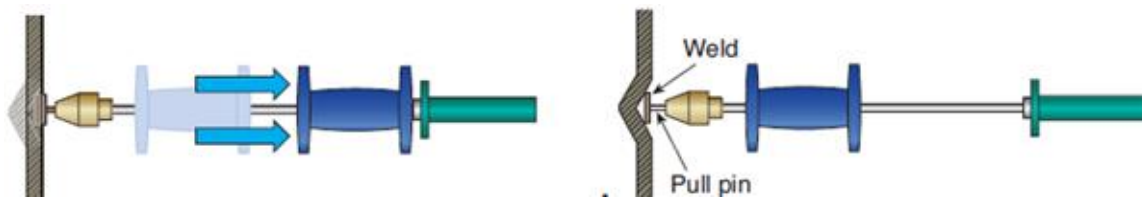

Figure1- 8 Dent pullers and pull rods

led hole and a hammer is slid on a steel shaft and struck against the handle. Tapping the slide hammer against the handle slowly pulls up the low spot.

Working with a dent puller is faster when a metal piercing tip is used. When the metal tip is forced through the sheet metal, the angular rings grip the metal as the hammer is

15	Ministry of Labor and Skills Author/Copyright	Automotive Body Repair and Paint Work	Version -III
			October, 2023

tapped against the metal. When the metal has been pulled back to shape, the tip can be backed out of the hole by turning it counter clockwise.

Pulling a small dent with a pull rod

A pull rod is used in this manner. The curved end of the pull rod is inserted in the drilled hole. A small dent or crease can be pulled up with a single pull rod. Three or four pull rods can be used simultaneously to pull up larger dents. A body hammer can also be used with a pull rod. The high crown of a dent can also be used with a pull rod. The low spot is pulled up simultaneously bumping and pulling returns the panel to its original shape with less danger of stretching the metal.

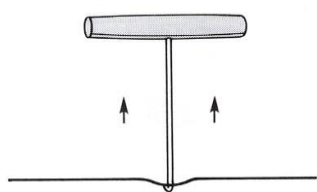

Figure1- 9 pull rod

It is important to close the holes created by using dent pullers and pull rods by soldering or welding. Simply patching the holes with body filler will not provide sufficient corrosion protection.

Suction cups

The suction cup is a simple tool that makes short work of shallow dents if they are not locked in by a crease in the metal. Simply attach the suction cup to the centre of the dent and pull. The dent might come right out with no damage to the paint and no refinishing

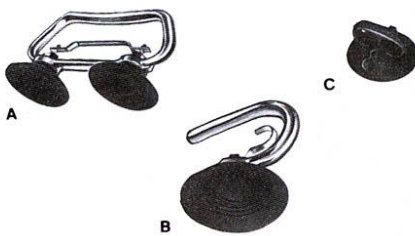

Figure1- 10 Suction cups

required. It is an easy tool to use and can make a simple repair. However, once a dent is locked in, some hammer and dolly work will be necessary to smooth the metal. Even so, the suction cup method is usually worth a try.

Scratch awl



A scratch awl is very similar in appearance to an ice pick, but the pointed steel shank is heavier. A scratch awl is used to pierce holes in their metal when a specific size hole is not required. It is also used to mark metal for cutting, drilling or fastening. A

Figure1- 11 Scratch awl

16	Ministry of Labor and Skills Author/Copyright	Automotive Body Repair and Paint Work	Version -III
			October, 2023

hammer can be used to lightly drive the awl through heavier metal. Keep the awl ground to a sharp point so it can be used effectively and safely in every job.

Metal cutting shears

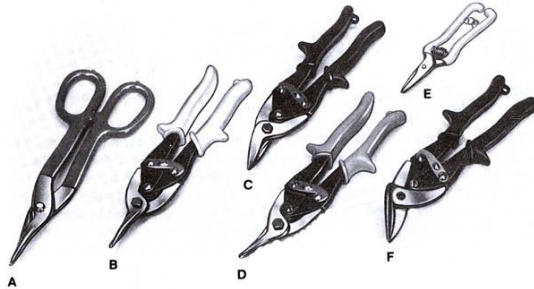

Most body repair technicians have at least one pair of shares or tin snips. Snips are used to trim panels or metal pieces to size. Several types of metal cutters are useful.

Figure1- 12 A. Tin snips, B. Straight cut, C. Right cut shear , D. Left cut shear

E. Light duty snips F. Aviation snips

Tin Snips

Tin snips are perhaps on most common metal cutting tool. They can be used to cut straight or curved shapes in heavy steel.

Metal Cutters

Metal cutters also called aviation snips, are used to cut through hard metals such as stainless steel. The narrow profile of jaws allows the snip to slip between the cut metal. The jaws are serrated to cut through the tough metal.

Panel Cutters

Panel cutters are special snips used to cut through body sheet metal. These are used to make straight or curved cut outs in panels that require spot repair for rust or damage. They are designed to leave a clean, straight edge that can be easily welded.

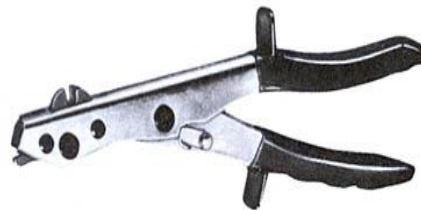

Figure1- 13 panel cutter

17	Ministry of Labor and Skills Author/Copyright	Automotive Body Repair and Paint Work	Version -III
			October, 2023

Rivet gun

Pop rivets are one of the handiest inventions for auto body work. They can be inserted in to a blind hole through two pieces of metal and then drawn up with a riveting tool, locking the pieces of metal together. There is no need to have access to the back of the rivets, and if enough rivets are used, the joint created is extremely strong. For any kind of sheet metal replacement such as rust hole repair, the pop rivet is by far the easiest and least expensive joining system available.

In fact, most body shops use rivets extensively, either as a permanent repair or as temporary fasteners. They are used as temporary fasteners before the replacement sheet metal is welded in places where extreme heat would distort the metal or create a safety hazard (such as around the gas tank). A good rivet gun does not cost much. The most commonly used rivets in bodywork are 1/8- and 3/16 inch. A few others of assorted sizes might be needed for special jobs.

A heavy-duty riveter, such as the one shown in is used to rivet hard-to-reach places and heavier mechanical assemblies such as a window glass regulator. It has long handles, a long nose, and sets 3/16 to 1/4 inch blind rivets.

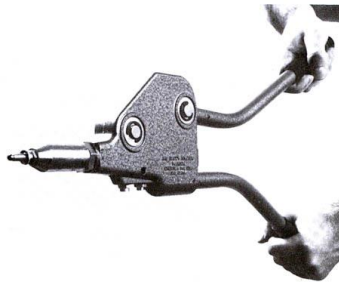

Figure1- 14 Rivet gun

Upholstery prongs

Any repair work that requires removing interior trim will be facilitated with an upholstery tool. This prong-shaped prying tool is used to slip under and pry up upholstery tacks, springs, clips and other fasteners.

18	Ministry of Labor and Skills Author/Copyright	Automotive Body Repair and Paint Work	Version -III
			October, 2023

Door handle tool

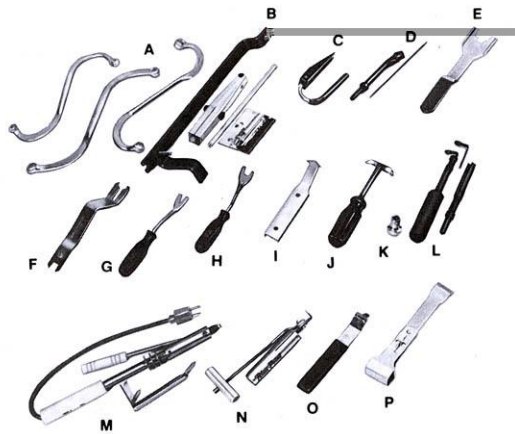

Interior door handles are often secured to the door panel by wire spring clips. Shaped like horseshoes, fit over the handle shaft and hold handle tightly against the interior panel trim. Clip pullers or door handle tools are needed to reach inside the door and remove the clip. Some door handle tools pull the clip put: Others push the clip off the shaft.

Figure1- 15 Door handle tools

- A) door hinge bolt wrenches B)door removal kit C & D)door panel remover E & F)door handle tool G & H)Trim pad remover D)window molding release tool
J)windshield locking strip installation tool K)window sash nut spanner socket
L)windshield remover M)hot-tip windshield remover kit N)windshield wiper removal tool O)windshield wiper tool P)all-purpose window scraper

Sheet Metal Brakes

Many body repairs require metal patches to be riveted or welded in to place. A tool that comes in handing and braking sheet metal is shown in Figure. This sheet metal brake bends sheet metal up to 20-gauge and sheet aluminium up to 16 gauge. Clean, smooth bends up to 90 degrees can be made with a brake. The brake is also used for cutting sheet metal to size. This is done by first bending the metal 90 degrees. Then the metal is worked back and forth by hand until the metal breaks along the crease.

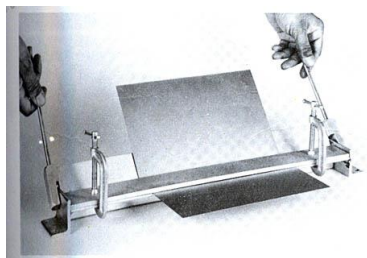

Figure1- 16 Sheet Metal Brake

19	Ministry of Labor and Skills Author/Copyright	Automotive Body Repair and Paint Work	Version -III
			October, 2023

Body Surfacing Tools

A number of surfacing tools are used to give a repair its final and contour. Some are used to shape the repaired metal. Others are used to apply and shape plastic body filler and putty.

Metal Files

After working a damaged panel back to its approximate original contour, a metal file is used to remove any remaining high spots. Two special files are necessary for most bodywork.

Reveal File

The reveal file is a small file that is available in numerous shapes. Generally it is curved to fit tightly crowned areas such as around wind shields, wheel openings, and other panel edges. The reveal file is pulled, not pushed, when used. Pushing causes the file to chatter, resulting in nicks and an uneven surface.

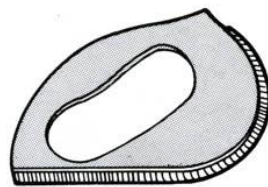

Figure1- 17 Reveal File

Body Files

Body files are used to level large surfaces. After a dent has been bumped or pulled back in to shape, the body file will hone down high spots and reveal any low spots that might require additional bumping. Keep in mind that it is possible to file through thin metal used in some vehicles.

The blade of the body file is held in a flexible holder with a turn buckle. The turnbuckle can be adjusted to flex the file. The flexible holder allows the shape of the file to fit the contour of the panel. Fixed file holders are also available for filling flat or slightly convex shapes.



Figure1- 18 Body Files

20	Ministry of Labor and Skills Author/Copyright	Automotive Body Repair and Paint Work	Version -III
			October, 2023

Surform File

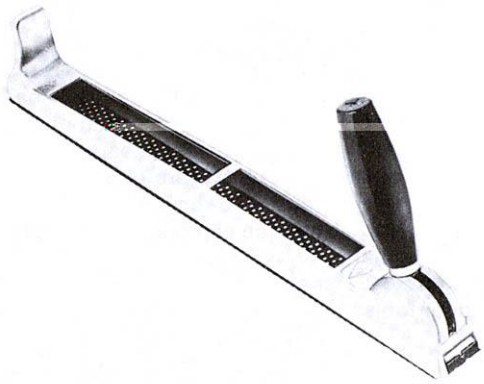

Body filler can be made level to the adjacent panel with a surform file. Commonly referred to as a "cheese grater," the surform file is used to shape body filler while it is semi hard. Shaping the filler before it hardens shortens the waiting period while the filler cures and reduces the sanding effort later in the repair process.

Figure1- 19 Surform File

Speed File

Once the body filler has hardened, the repair can be shaped and levelled with a speed file. A speed file is a rigid wooden holder about 17 inches long and 2-3/4 inches wide. Also called a flat boy, the speed file allows a repair area to be sanded quickly with long, level strokes. This eliminates waves and uneven areas.

The lightweight aluminium sander shown in Fig 3-88A is designed to quickly level body filler. The extra long length helps avoid creating a waxy surface. The sander also flexes to match the panel contour. Adhesive backed sandpaper is applied from a roll. This particular sander can also be attached to a straight-line air sander.

Spreaders and Squeegees

Spreaders and squeegees are two important tools used in auto body resurfacing. Spreaders are used to apply body filler. Spreaders are made of rigid plastic and are available in various sizes. Be sure to use one that is large enough to apply plastic filler over the repair area before the filler begins to set up.

A squeegee is a flexible rubber block approximately 2 inches by 3 inches and 3/16 inch thick. Squeegees are used to apply glazing putty and light coats of body filler. They are also used when wet sanding to skim water and sanding grit from the repair area.

21	Ministry of Labor and Skills Author/Copyright	Automotive Body Repair and Paint Work	Version -III
			October, 2023

1.4. OHS requirement

1.4.1. Shop safety practices and Health Protection

The most important considerations in any repair and refinishing shop should be accident prevention and safety carelessness and the lack of safety habits cause's accidents. Accidents have far-reaching effects, not only on the victim, but on the victim's family and society in general. More importantly accident can cause serious injury, temporary or permanent or even death. Therefore it is the obligation at all shop workers, instructors and students to foster and develop a safety habit to protect the health and welfare of those involved.

Air passages and lungs protection

Abrasive dust vapor from caustic solutions and solvents spray mist from undercoats and finishes- all present dangers to the air passages and lungs, especially for workers who are among them day in, day out. The cartridge filter or organic vapors type of respirator, which covers the nose and mouth, is equipped with a replacement cartridge that removes the organic vapors by chemical absorption painting without this equipment it is harmful to our respiratory organ.

The dust respirator or mask is worn to protect against dust from sanding and grinding. These operations in the body shop create dust can that can cause bronchial irritations and possibly long terms lung damage such as silicosis (well known in mining areas). Keep in mind that these respirators are good for removing solid particles from the air and have little if any ability to remove vapors should never be worn when spray painting use cartridge filter.

Eye and face protection

Eye protection is required where there is a possibility of an eye injury from flying particles, chips, and so forth clear protective safety goggles, glasses or face shields should be worn when using grinders, disc sanders, power drills, pneumatic chisels, removing shattered glass, or when working underneath the auto. When they are in the metal working or painting areas of the shop locations there is always the possibility of flying objects, dust particles or splashing liquids entering the eyes. Not only can this be painful it can also cause loss of sight. Remember eyes are irreplaceable. Get in the habit of wearing safety goggles, glasses, or face shields in the working areas.

22	Ministry of Labor and Skills Author/Copyright	Automotive Body Repair and Paint Work	Version -III
			October, 2023

A welding helmet or welding goggles with the proper shade lens must be worn when welding. These will protect the eyes and face from flying molten pieces of steel and from harmful light rays.

Ear protection

Panel beating the piercing noise of sanding, the radio blaring full-blast-it is impossible to hear anything else. It is enough to deafen a person and that is exactly what it will do if proper precautions are not taken. When in metal working areas, wear earplugs or ear muffs to protect the eardrums from damaging noise levels.

Body and hand protection

Loose clothing unbuttoned shirt sleeves, loose Jewelry are very dangerous in body shop. Instead wear approved shop work clothes. Trousers should be long enough to cover the top of the shoes. This will prevent sparks from going down in to the shoes. Especially when using welding equipment. The harmful effects of liquid undercoats and finishes on the hands can be prevented very effectively by wearing proper gloves. When using any body or paint shop chemicals, be sure to wash the hands with soap and water before eating or smoking.



Figure1- 20 Body protection equipment

A. Welders gloves for electric arc welding, B. TIG and gas welding gloves Working gloves, C. Leather jacket for welding, D. Leather trousers with belt E. Arm protector pair F. Leather apron G. Safety Shoe, H. Arc welding face shields and glasses, I. Gas welding goggles J. Ear Protection

23	Ministry of Labor and Skills Author/Copyright	Automotive Body Repair and Paint Work	Version -III
			October, 2023

Foot protection

Wear safety work shoes that have metal toe inserts and no slips. The inserts protect the toes from falling objects, the soles help to prevent falls. In addition, good work shoes provide support and comfort for someone who is standing for a long time. Never wear plastic (rubber) or sandal none of this shoes provided adequate protection in a body shop.

Faulty work habits

- ✓ Smoking around fuel and solvents
- ✓ Incorrect handling of paint, thinners, solvents, flammable liquids etc...
- ✓ Blocking exits. A block exit could mean serious injury or even death during an emergency case such as fire.

Misuse of equipments

- ✓ Incorrect safety guarding of moving machinery
- ✓ Misuse of flexible electric cords or worn cords. When used through holes the may cause fire
- ✓ Improperly stored composed gas cylinders
- ✓ Using hand held electric tools improperly grounded

Misuse of hand tools

- ✓ Keeping hand tools dirty and in poor conditions
- ✓ Improper storing of hand tools
- ✓ Using defective hand tools
- ✓ Keeping sharp tools in pockets

24	Ministry of Labor and Skills Author/Copyright	Automotive Body Repair and Paint Work	Version -III
			October, 2023

Self-check 1.1

Directions: Answer all the questions listed below.

Part I: Fill in the blank space

1. _____ is characterized by its roof, which extends straight back for the length of the vehicle.
2. _____ is assembled on to the frame with mounting brackets which have rubber bushed bolts to hold the body to the rigid frame.
3. _____ is a simple tool that makes short work of shallow dents if they are not locked in by a crease in the metal.
4. _____ is by far the easiest and least expensive joining system available.
5. _____ is the portion of an automobile that sits above the passenger compartment.

Part-II: Choose the correct answer from the given alternatives

1. Which one is from the following body shape has no door pillars and, depending on the make, can be purchased with or without a back window?
 - A. Hard top
 - B. Sedan
 - C. Convertible top
 - D. All
2. What is the purpose sledgehammer?
 - A. knock damaged metal roughly back in to shape and to clear away damaged metal
 - B. For the first stages of re-forming damaged sheet meta
 - C. Pounding sheet metal backs in to shape
 - D. A & B
3. How can prevent the happening of accident in our work shop?
 - A. By practicing safety
 - B. By using defective hand tools
 - C. By Keeping sharp tools in pockets
 - D. All
4. Which one is from the following body tool used to mark the location?
 - A. Suction cups
 - B. Scratch awl
 - C. Punches and Chisels
 - D. All
5. Which one is from the following characteristics of conventional body over frame?
 - A. High amount of energy are absorbed during a collision
 - B. Under surfaces of the body are protected over rough roads

25	Ministry of Labor and Skills Author/Copyright	Automotive Body Repair and Paint Work	Version -III
			October, 2023

- C. The vehicle profile is generally high of the ground
- D. All

Part-III: Answer the following questions accordingly.

1. Properly differentiate body and hand protection, eye and face protection and air passages and lungs protection?
2. Write Characteristics of conventional body over frame?
3. Write Components of vehicle body panels
4. Write at least five body tools and there functions?
5. Write basic body shapes and there functions?

26	Ministry of Labor and Skills Author/Copyright	Automotive Body Repair and Paint Work	Version -III
			October, 2023

Unit Two: - Repairing vehicle body panels and components

This unit is developed to provide you the necessary information regarding the following content coverage and topics

- Remove and tag body panels and components.
- Align body panels and components.
- Replace body panels and components

This unit will also assist you to attain the learning outcomes stated in the cover page. Specifically, upon completion of this learning guide, you will be able to:

- Removing and tagging body panels and components.
- Describe Align body panels and components.
- Replacing body panels and components

27	Ministry of Labor and Skills Author/Copyright	Automotive Body Repair and Paint Work	Version -III
			October, 2023

2.1. Removing and Tagging body panels and components

A collision-damaged vehicle can require a variety of repair operations. Repair steps depend on the nature and location of the damage. Panels with minor damage often can be straightened and filled with plastic. Minor bulges, dents, and creases can be fixed using the techniques discussed in earlier chapters. However, quite often the damage is too extensive and part replacement is the only logical solution.

This chapter covers replacement procedures for hoods, fenders, bumpers, deck lids, trim pieces, and similar bolt-on parts. Many major parts bolt on to the vehicle.

Keep in mind that on-the-job experience is the only way to become competent at body part removal and replacement (*part R&R*). Sometimes you must remove one part at a time. In other instances, it is better to remove several parts as an assembly. This chapter will give you the background information to make this learning process



Figure 2- 1 Damaged vehicle

Remove body panels and components

Generally, you start by removing large, external parts first. For example, if the front end has damage, you must remove the hood first. This gives you more room to access rear fender bolts. It also allows more light into the front to aid in finding and removing hidden bolts. Use this same kind of logic to remove parts efficiently

If in doubt about how to remove a part, refer to the vehicle's service manual or computerized service information (Mitchell, for example). Factory service information normally has a body repair section. The body repair section of the manual or computerized information

explains and illustrates how parts are serviced. It gives step-by-step instructions for the specific make and model vehicle, as well as bolt locations, torque values, removal sequences, and other important information. For example, look at *Figure 2- 2*. The rear quarter panels on this car bolt in place. Most cars have welded quarter panels. This car also has aluminum body panels that must be repaired differently than steel.

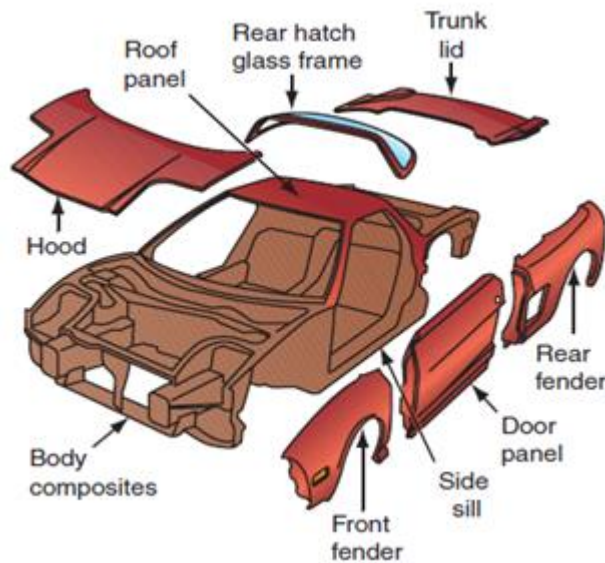

Figure 2- 3 Body panel components

Hood service

The hood provides an external cover over the front of the vehicle. It is one of the largest, heaviest panels on a car or truck. In a front-engine vehicle, it provides access to the engine compartment. With a rear-engine car, it serves as a deck or trunk lid over a storage compartment (*Figure 2- 4*).

Before removing the hood, analyze the condition of its parts. Open and close the hood. Check for binding and bent hinges. If applicable, inspect hood alignment with the fenders and cowl. This will help you determine what must be done during repairs.



Figure 2- 5 panel removed vehicle

Hood removal

To remove a hood, first disconnect any wires and hoses. Wires often connect to an under hood light. Hoses might run to the hood for the windshield washer system.

A **hood prop tool** is a rubber-tipped extension rod for holding the hood open as you remove the hood shocks and other hood parts. It will help keep the hood from falling while you work.

Hood struts, or shocks, are spring-loaded rods used to hold the hood open when working in the engine compartment. With the hood propped open, you next remove the struts. Various methods are used to secure the ends of the hood struts (clips, small nuts, and so on). *Figure 2- 6* gives a typical service manual example of how to remove the hood struts.

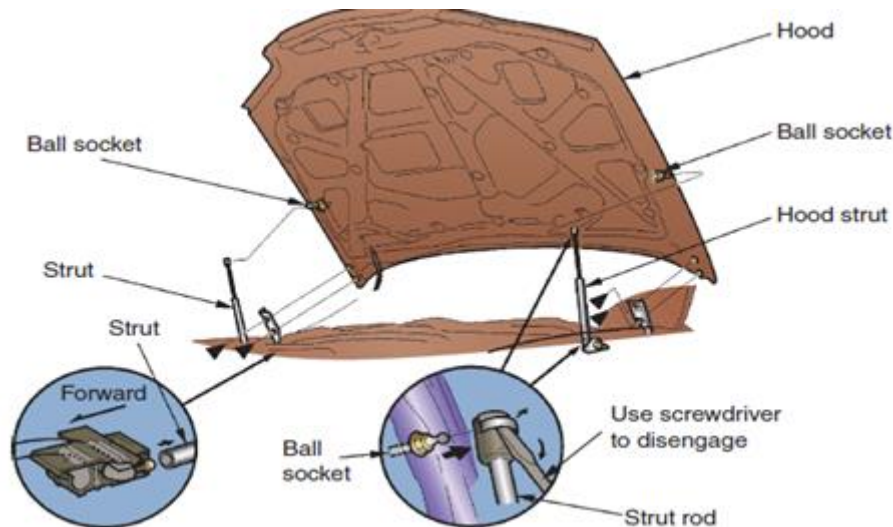

Figure 2- 7 Removed hood

Next, remove the hood hinge bolts. If the hood is not badly damaged and will be reused, mark the hood hinge alignment. To mark the hood, scribe alignment marks around the sides of the hood hinge where it contacts the hood. You may also want to mark the hinge where it mounts on the body. You can then use these marks to rough adjust the hinges and hood during reinstallation. To prevent part damage, have someone help you hold the hood. Place your shoulder under the hood while holding the bottom edge of the hood with one hand. This will keep the hood from sliding down and hitting the windshield, cowl, or fenders. Use your shoulder to support the weight of the hood. With your free hand, remove the hood bolts. Your helper should do the same. Do not let the weight of the hood rest on the bolts as you loosen them (*Figure 2- 8*).

Note the location of anybody shims or spacers that help adjust the hood. If there is no major damage, you may need to reinstall the spacers in the same locations. Place the hood out of the way, where it cannot get hit, scratched, or knocked over.



Figure 2- 9 hinge removing

Hood hinge Remove and Reinstall

Hood hinges allow the hood to open and close while staying in alignment. They must hold considerable weight and keep the hood secure while driving. Hood hinges are often damaged in a frontal impact.

If bent badly, you will have to replace the hood hinges. If equipped with large coil springs, you may also have to install the old springs on the new hinges. A hood hinge spring tool should be used to stretch the springs off and on. It is a hooked tool that will easily pry the end of a spring off and onto its mount.

31	Ministry of Labor and Skills Author/Copyright	Automotive Body Repair and Paint Work	Version -III
			October, 2023

If needed, unbolt the hinges from the inner fender panels. Again, mark their alignment if the anybody structure is not badly damaged from the collision.

If hood hinges are bent or damaged, install new ones. Align your marks and snug down the body-to-hinge bolts. You may have to adjust the hood height at these bolts later.

Install the new or repaired hood in reverse order of removal. Again, have someone help you hold the hood while installing its bolts. Snug down the hinge-to-hood bolts but do not tighten them fully. You will need to adjust the hood location later. A misaligned hood is shown in *Figure 2- 10*

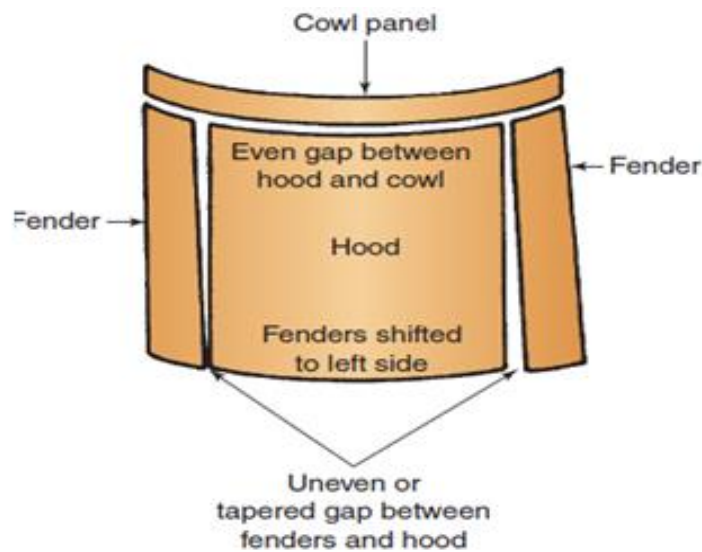

Figure 2- 11 Hood

Fender removal

To remove a fender, find and remove all of the bolts securing it to the vehicle (*Figure 2- 12*). Also remove any wires going to fender-mounted lights. Fenders are usually bolted to the radiator core support, inner fender panels, and cowl. Bolts are often hidden behind the doors, inner fender panels, and under the vehicle.

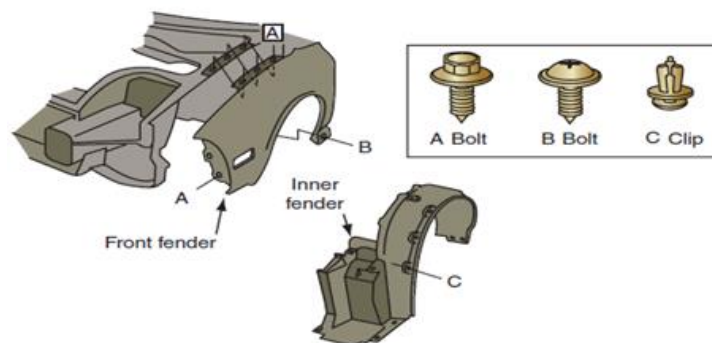

Figure 2- 13 removal fender

If the old fender has factory-installed fender shims or spacers, note their locations during disassembly. If there is no major uni-body or frame damage, reinstalling the fender shims in their original locations will help you more quickly realign the fender after repairs.

With all of the bolts removed, carefully lift the fender off. Transfer any needed parts (trim, body clips, and so forth) from the old fender over to the new fender.

You will usually have to send the fender to the refinishing area for pre installation paint edging. During *paint edging*, all ends, corners, edges, and sometimes the rear of the fender panel should be scuff sanded, primed, and painted. The surfaces of the fender are often painted before installation on the vehicle. These areas would be difficult or impossible to paint after the fender has been bolted to the vehicle.

Deck lid and hatch service

The deck lid is very similar to the hood in construction. Two hinges connect the deck lid to the rear body panel. The trailing edge is secured by a locking latch. Deck lid or hatch door removal and replacement are similar to hood R&R (Figure 2- 9).

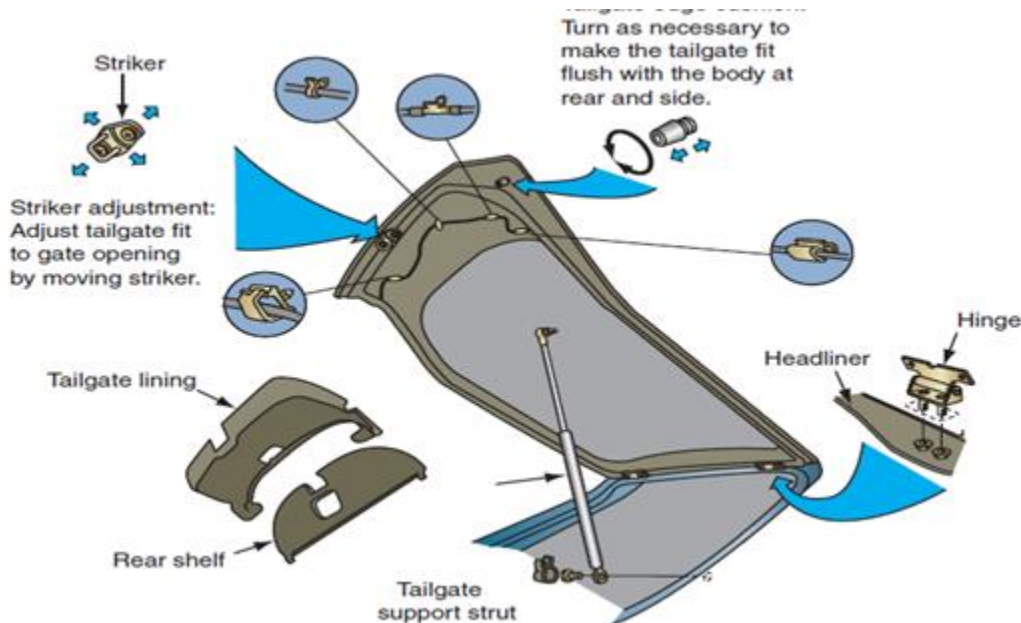

Figure 2- 14 Deck lid and hatch service

The deck lid must be evenly spaced between the adjacent panels. Slotted holes in the hinges and/or caged plates in the deck lid allow it to be moved. To adjust the deck lid forward or rearward, slightly loosen the bolts on both hinges. Close and adjust the deck lid as required.

Then raise the lid and tighten the bolts.

Weather stripping is a rubber seal that prevents leakage at the joint between the movable part (lid, hatch, or door) and the body. To prevent air and water leaks, the deck lid must contact the weather stripping evenly when closed. The latch must be adjusted so that it holds the lid or hatch closed against the weather stripping.

Deck lids and hatches usually do not have exterior or interior door handle mechanisms. They operate with a key (or instrument panel switch on powered units) and lock mechanism.

Lock cylinders contain a tumbler mechanism that engages the key so that you can turn the key and disengage the latch. When you insert your key into a door or lid, it engages the lock cylinder. The lock cylinder then transfers motion to the latch.

Lid torsion rods are spring steel rods used to help lift the weight of the lid. They extend horizontally across the body and engage a stationary bracket. Some torsion rod brackets have adjustment slots. You can change tension on the torsion rods by moving them in these slots (Figure 2- 15).

Removing a door panel

Removing a door panel from a car may seem like a difficult thing to do, but it’s actually quite simple and there are many varieties of door panel clips and many clip removal tool kits available at reasonable prices. Start by removing the control panel and door latch with a screwdriver and disconnecting their electrical wires. Then take off the rest of the trim pieces that may be concealing the panel’s fastening screws and use a screwdriver to take out all of the screws holding the panel in place. Take a firm hold of the panel, and pull it straight off. It’s that easy!

Tailgate removal

The tailgate removal or repair process is pretty straightforward. You would need to identify the malfunctioning part(s) and then replace them. There are plenty of GM tailgate repair/removal tutorials floating around the internet.

Tag body panels and components.

Fastened parts are held on a vehicle by bolts, nuts, screws, clips, and adhesives. The methods of fastening parts to cars and trucks have changed over the past few years. Many parts that were held on with bolts and screws in the past now snap-fit into place. Plastic retainers now hold these parts onto the vehicle. This was done to save time during vehicle manufacturing. The part is simply pressed or “popped” into position on the assembly line.

The panels and parts that typically fasten in place without welding are shown in *Figure 2- 16*.

34	Ministry of Labor and Skills Author/Copyright	Automotive Body Repair and Paint Work	Version -III
			October, 2023

Refer to the estimate or shop work order to get guidance on how to start work. The estimator will have determined which parts need to be repaired and which should be replaced. Use this information and shop manuals to remove and replace parts efficiently.

The estimate is a critical reference tool when doing repairs, and it must be followed. The insurance company and estimator have both determined which parts to repair. If you fail to follow the estimate, the insurance company may not pay for your work.

The estimate is also used to order new parts. You should make sure all ordered parts have arrived. Compare new parts on hand with the parts list. If any parts are missing, have the parts person order them. This will save time and prevent your stall from being tied up while waiting for parts to be delivered.

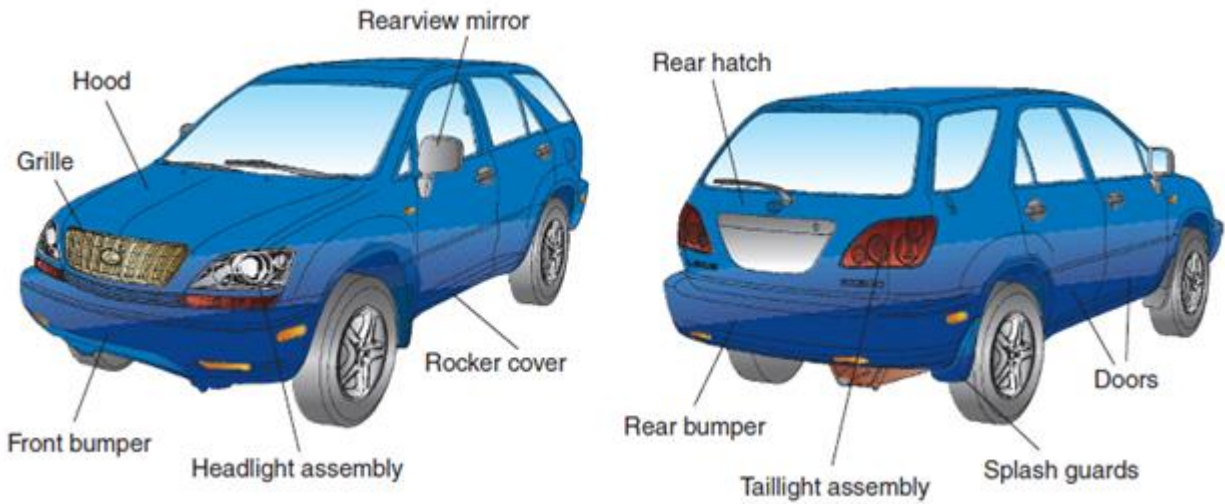

Figure 2- 17 fastening parts to cars and trucks

2.2. Align body panels and components

Alignment is squaring the damaged body of a motor vehicle by restoring its correct shape and dimensions. Misalignment may be checked by observation, but measurements are more accurate. The best measuring method of checking, known as X-checking, is simply an application of the principle that the diagonals of a true rectangle are equal in length. Some areas that must be checked, such as door openings, the front section (area between the cowl hinge pillars), and the center section (area between the central pillars), are not in themselves square, but rectangles may be laid within them which provide good diagonal tests.

- The measuring device, called a tram (Figure 2- 18), is a telescoping tube equipped with an extension clamp which fixes it as the measurement of one diagonal for comparison with another.

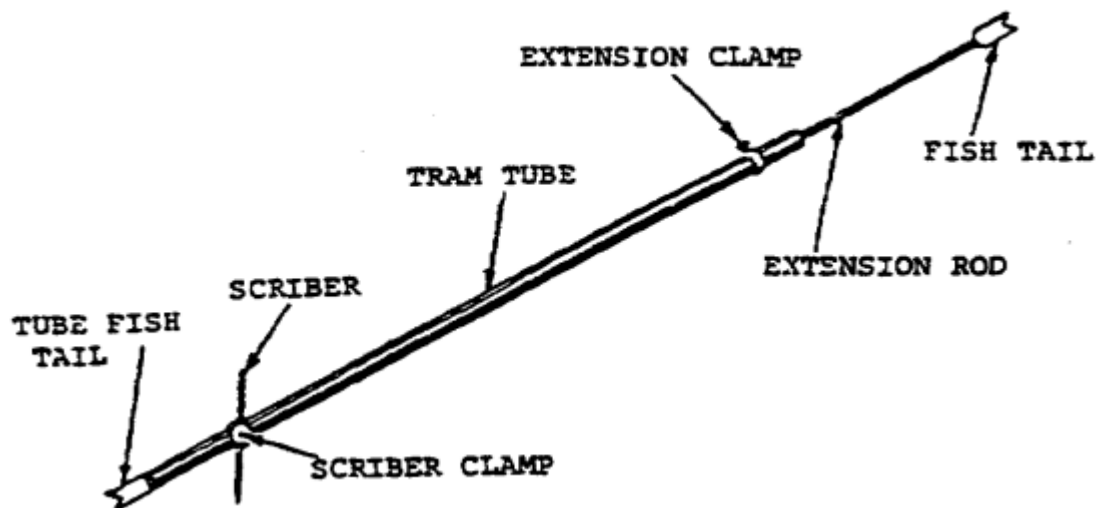

Figure 2- 19 A Tram

Body panels repair procedures and straightening and squaring operations all apply, including the use of the hydraulic jack or other equipment. Avoid concentrating stresses in one spot by the use of blocks or plates of wood or metal in order to distribute the force. Avoid use of flame welding in repair, if possible, and do not apply excessive heat to the main frame members, as annealing and loss of strength may result. Most collision damage may be repaired by the use of jacks and bumping blocks or irons to reshape the damaged panels back to their original form. Usually, it is uneconomical to repair a body which has sustained damage to the main structural members severe enough to collapse the box section members.

Body and Fender Repair Techniques

A. General method

Restoring vehicle body panels of sheet metal to their normal contour after they have been damaged is referred to as metal bumping or dinging. Every job involved in metal bumping, requires fine handwork. To become a good metal body repairman, mastery of each phase of work is required. In collision work, use of the hammer is one of the most important functions.

B. Analyzing Damage

The ultimate success of any collision repair job depends on the accuracy of the analysis of what is damaged and how it occurred. Collision work must be approached on this basis, but goes a step on operation sheet. Not only must you first determine what is wrong, but you must establish how it got that way and the order in which it happened.

Although the straightening of body panels and fenders comprises the greatest volume of collision work, collision damage also occurs to the mechanical parts of the vehicle. The repair of mechanical parts is an important part of the total repair of collision damage. When you are finished repairing a vehicle damaged in collision or one that has turned over, it must run well, it must steer well, the brakes must operate properly, and all of the electrical units must be in operating condition. Although the correction of mechanical difficulties caused by the collision involves other skills and techniques than are practiced by the collision expert, he cannot ignore them and must provide for their correction.

Using body hammers

The **body hammer** is designed to strike sheet metal and rebound off its surface as a means of straightening minor bumps and dents. It is not designed to be driven down, as you would in driving a nail. A driving action would create additional damage in the sheet metal (*Figure 2- 20*).



Figure 2- 21 straightening minor bumps and dents

37	Ministry of Labor and Skills Author/Copyright	Automotive Body Repair and Paint Work	Version -III
			October, 2023

The secret of metal straightening is to hit the right spot at the right time with the right hammers, and with the right amount of force. When using a body hammer, whether one with a metal or plastic head, swing in a circular motion at your wrist. Do not swing the hammer with your whole arm and shoulder.

Hit the part squarely and let the hammer rebound off the metal. Space each blow $\frac{3}{8}$ to $\frac{1}{2}$ inch (9.5 to 13 mm) apart until the damaged metal is level. The face of the hammer must fit the contour of the panel. Use a flat face on flat or low-crown panels. Use a convex-shaped or high-crown face when bumping inside curves. Heavy body hammers should be used for roughing out the damage. Finishing hammers, or dinging hammers, should be used for final shaping. The secret to finish hammering is light, rapid taps. It is also important to hit squarely. Hitting with the edge of the hammer will put additional nicks in the metal.

Body straightening techniques

Theory and analysis will tell you what is wrong. After that you must have the basic skills to repair the damage. Then you must know how to put these things together to produce the overall results required of a professional body technician. You must develop a good procedure for repair. Good procedure saves a great deal of “technician created” damage so that overall repair time is kept to a minimum for higher profits.

The repair procedure begins with a diagnosis of the damage. The actual work on the metal begins with the rough-out stage. Rough-out means to remove the most obvious damage to get back the original part shape. It must be done properly if finishing operations are to succeed.

When finishing operations are started too soon, it becomes difficult to do a good job.

Roughing out the damage can be as simple as using a rubber or plastic hammer on the edge of a door. Carefully placed hammer blows on the back of the panel may be all that is needed to straighten minor damage. When using hammer blows, always grasp the end of the handle and make sure the hammer head strikes the metal squarely (*Figure 2- 22*).

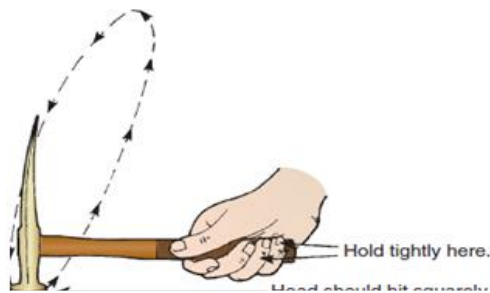

Figure 2- 23 Body straightening techniques

38	Ministry of Labor and Skills Author/Copyright	Automotive Body Repair and Paint Work	Version -III
			October, 2023

The rough-out operations change with each damage, with each vehicle, and with each location of the damage on the car. In other words, the rough-out is very important to the particular vehicle being worked on.

The rest of the chapter is devoted to explaining some of the common skills used by body technicians from the rough-out stage of repair up to the body filling stage.

The buckles and creases in a dented panel can be un locked in a variety of ways. On panels where the backside of the panel is accessible, hammers and dollies or spoons are used for the initial roughing out. On areas where the back side of the panel is difficult to reach, slide hammers, picks, and welded studs can be used to reverse the damage.

Always remember the rule: “First damage in, last damage out,” or “Work indirect damage first, work direct damage last.” This means that you must repair the damage away from the point of impact before finally removing the worst damage at the point of impact. If you are using a hammer and dolly to work a small dent, start working around the perimeter of the dent and gradually work your way in to the deepest part to remove it last. If you work backward, trying to hammer out the deepest point of the dent first, you will not be able to work the dent out as smoothly.

Bumping dents with dollies

A dolly is a heavy steel block with various shapes on each side for straightening sheet metal. In the rough-out phase, a heavy steel dolly block is sometimes used as an impact tool. A dolly is often used as a striking tool on the back of panels. Sometimes you can reach into obstructed areas with a steel dolly more easily than you can with a hammer. You can strike the back side of a dented panel with the dolly to raise low areas and to unroll buckles (*Figure 2- 24*).

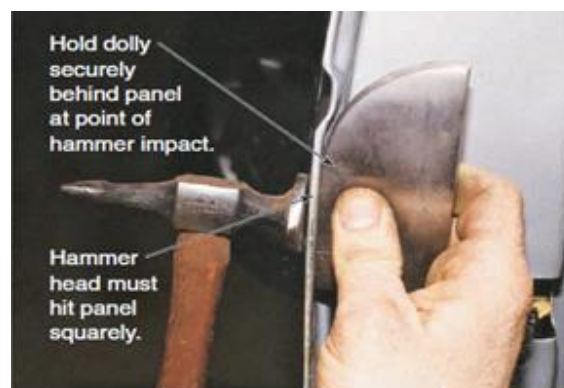

Figure 2- 25 Straightening panel by using dollies

39	Ministry of Labor and Skills Author/Copyright	Automotive Body Repair and Paint Work	Version -III
			October, 2023

The contour of the dolly must fit the contour of the back side of the damaged area (*Figure 2- 26*). This will make the blows from the dolly force the metal back in to the original contour. If the wrong surface hits the panel (the sharp edge of the dolly, for example), you will further damage the panel (*Figure 2- 27*).

Use accurate hammer blows. Start out with light blows from the dolly while watching the front of the panel. Make sure you are hitting exactly where needed. Gradually increase the force of your blows to raise the damage. It is normally better to use several moderate blows than to use a few hard blows. Numerous well-placed blows with the dolly will let you better control how you work the metal back into shape.

As you hit the panel, the dolly tends to rebound slightly. This creates a secondary lifting action on the metal. You can increase rebound blows by releasing pressure as soon as the dolly hits the panel. Using a large dolly will also increase impact and rebound forces on the panel (*Figure 2- 28*).

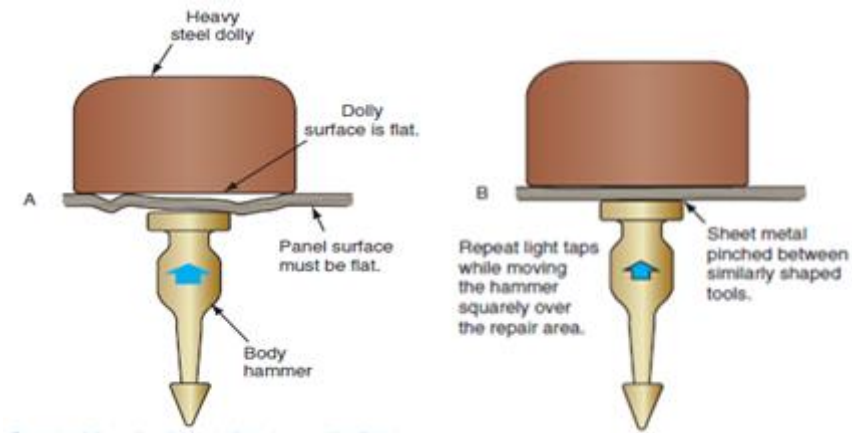

Figure 2- 29 Using light hammer blows from the front to remove the damage

Picking dents

There are several methods of picking up metal with the use of a pointed (not necessarily sharp) tool. Picking dents often involves final straightening of very small areas of damage with the pointed end of a body hammer or with a long rod that has a curved, pointed tip (*Figure 2- 30*).



Figure 2- 31 A pointed head or pick on hammer

The pick on a body hammer is often used to lower any small, high spots in the repair area. Very light, carefully placed blows with the point of the hammer will lower any dimples still sticking up in the repair area.

Long picking tools can also be used to pry up metal in areas that cannot be reached with a dolly or spoon. A car door is a good example. A pick can sometimes be inserted through a drainage hole or a hole drilled behind the door gasket. This eliminates the need to remove the inside door trim or to drill holes in the outer panel for pulling the dent. Picks are used during paint less dent removal (removing small body dings or dents without painting the panel).

When prying with a pick, be careful not to stretch the metal by exerting too much pressure. Deep creases should be straightened by starting from the shallow area and working toward the deep area. Start with the original point of contact or the lowest point. Slowly pry the crease up. On larger dents, use a flat blade pick rather than a pointed one. Tap down pressure areas while prying up low tension areas.

- **Hood height adjustments**

To correct the alignment of the hood up and down at the rear, slightly loosen the bolts holding the hinges to the fenders or cowl. Then, slowly close the hood and raise or lower the rear edge of the hood as necessary. When the rear of the hood is level with the adjacent fenders and cowl, open the hood and tighten the bolts. Once the rear of the hood is adjusted to the correct height, the adjustable stops must be checked. The rear stops must be adjusted to touch lightly against the hood. This eliminates hood movement and rattle. The front stops control the height of the front of the hood. Turn the stops in or out until the front of the hood is even with the top of the fenders. Be sure to retighten the locknut on the stop after adjustment.

41	Ministry of Labor and Skills Author/Copyright	Automotive Body Repair and Paint Work	Version -III
			October, 2023

Remember, hood adjustments are made at the hinges, at the adjustable stops, and at the hood latch. You can adjust the hood up or down, side to side, and forward or rearward. This allows you to align the hood vertically and horizontally with the fenders and cowl. Refer to (*Figure 2-32*). Hood hinge adjustments control the general position of the hood in relation to the fenders and the rear hood height. By loosening the hood-to-hinge bolts, you can move the front end of the hood right or left. You can also slide the hood to the front or back. Tighten them down when the hood is centered in the opening. There should be an equal gap around the hood's perimeter. There should also be enough of a gap at the back edge to clear the cowl panel



Figure 2- 33 Alignment of the hood

Correct collision damage

To correct collision damage in a motor vehicle, it requires a strong force opposite to the direction of the impact. Powerful portable jacks have been developed to replace crowbars, planks and other makeshifts that were used for years to force damaged frames and bodies back into shape. The portable hydraulic jack shown in (*Figure 2- 34*) is capable of exerting a 10 ton force. It consists simply of a hydraulic cylinder connected to a hand pump through a hose. It is provided with attachments for pushing, pulling, bending, clamping, or spreading, which can be used singly or in combinations.

42	Ministry of Labor and Skills Author/Copyright	Automotive Body Repair and Paint Work	Version -III
			October, 2023

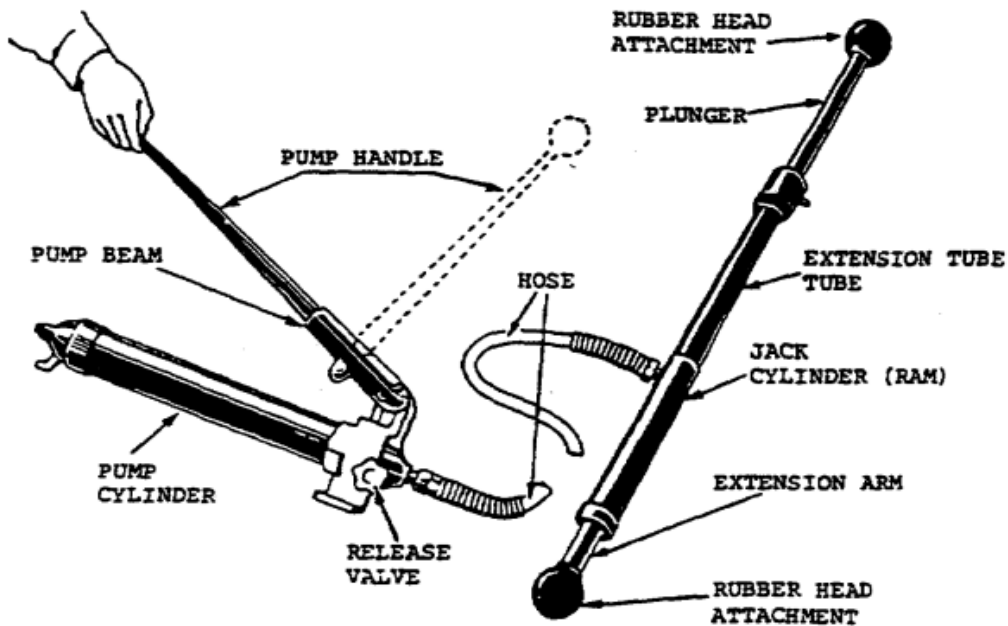

Figure 2- 35 Portable hydraulic jack

Before using the jack, size up the job to determine the direction of the damaging force. If the frame has been twisted, align this first, removing the body if necessary. Make a setup using the ram and its attachments to apply hydraulic force, reversing the force of the damaging impact.

To operate the jack, insert the handle into the pump beam either horizontally or vertically. Close the release valve, turning it by hand as far as possible to the right. The down stroke of the handle forces oil through the hose to the ram, causing the plunger to travel outward under pressure. To release the pressure, turn the release valve on the side of the pump to the left.

Metal Shrinking

Shrinking is Stretching of the metal beyond its elastic limit takes place. When body panels and fenders formed in dies under high pressure, the sheet metal is stretched and drawn. This displaces the molecules of metal. The high pressure of the press squeezing the metal locks the molecules in a new position. They will resist any subsequent force which tries to change their arrangement. Metal has some elasticity; that is, metal can be bent or twisted without permanent disarrangement of the molecules. When the force thus applied is removed, the elasticity of the metal will cause it to resume the shape that it had when the molecules of the metal were locked together in the dies. The body repairman must avoid destroying this natural tendency of the metal to return to its original shape. This is not always possible in collisions where the normally smooth surface is badly creased. Creases represent a portion of the metal that has been

distorted beyond its elastic limit and in which the molecules have been displaced. They are no longer locked together in the same arrangement that was given to them in the forming die.

A. Hot Shrinking

Hot shrinking is a simple process, but it requires careful timing and proper tools. Tools required are those which are used for many other operations in body work; i.e., a welding torch that is equipped with the same size tip as used for welding the thickness of sheet metal being worked on; a body hammer or mallet; shrinking dolly; a container of water, and a sponge or rag.

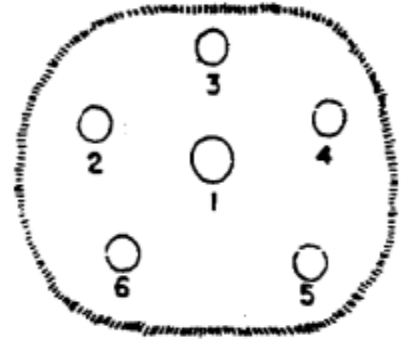

Figure 2- 36 sequence of shrinking panel

B. Cold Shrinking

Cold shrinking is a process in motor vehicle bodyworks. Compared with hot shrinking, cold shrinking is a longer process, but it is the most preferred method and most common especially where the stretched area is bigger. Cold shrinking is mostly done by use of a dolly hammer. The rough surface is then filled using a body filler or a body solder in order to give a smooth finish. This is a method of panel beating where heating is not done to the stretched panel. This method is mostly suitable for integral cars with integral body panels such as hatchbacks.

2.3. Reinstalling body panels and components

Panel replacement is often the only permanent remedy for corrosion damage. For instance, a rusted-out rocker panel and cab corner on a truck would be repaired by cutting away the rusty metal and welding new partial panels in place.

At this point it should be emphasized that great accuracy is required in straightening work in order that doors and windows will operate correctly, and in the case of front end work the front suspension cross member is made to unusually close limits. This is necessary to insure proper front wheel alignment. Therefore, in many cases it is better practice to replace a member than to attempt to straighten 'it.

The alignment of a new front fender (*Figure 2- 37*) is simplified, for in most cases the bolt holes are elongated so that the position of the panel can be shifted and correctly aligned. In general,

only front fender panels are bolted in position, while rear fender panels, or rear quarter panels, as these are known, are generally welded in position

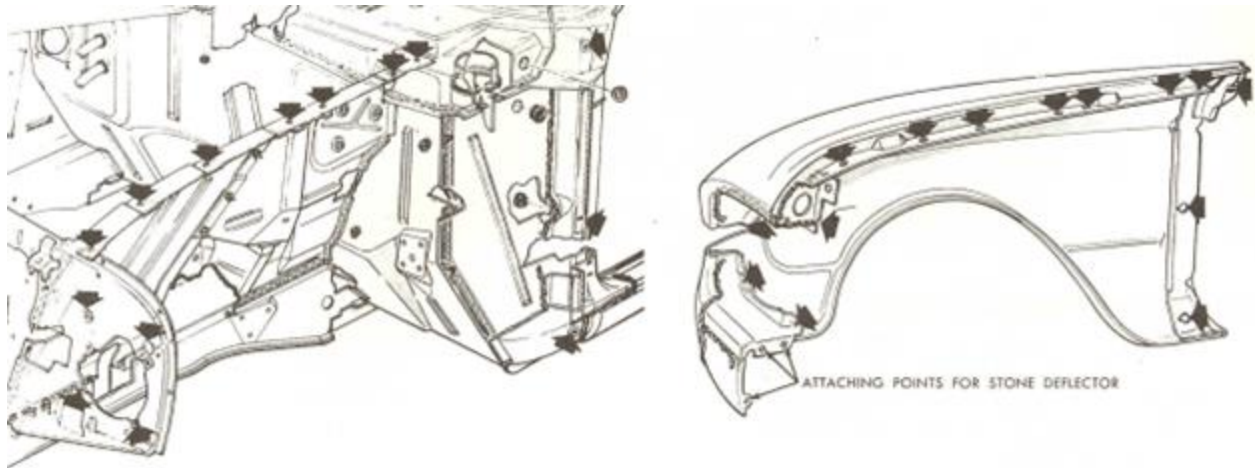

Figure 2- 38 Attaching point of fender and stone deflector

2.3.1. Reinstalling complete panel

Typical service panels are shown in (Figure 2- 39) If the complete panel is to be replaced, the old panel should be removed by cutting along the weld, if fusion welded in place, or by drilling out the spot welds, if it is spot welded in place. Car and body manufacturers have the panels welded at different places, and it is necessary to examine the body to determine where the welds are located in each case. In addition, collision manuals will give diagrams of the panels for the different makes and models of cars which indicate where these welds are located.

Before cutting out the old panel, it is important that the damage to the area be re stored to its original shape and alignment. This can be checked by comparison with the other side of the vehicle.

After removing the old damaged panel, the inner panel, such as the wheelhouse, rocker and other inner panels are carefully checked and straightened or replaced, as the case may require. The new outer panel is placed in position by means of vice-grip pliers, or by C-clamps.



Figure 2- 40 Drilling out spot welds at front edge of roof

The welder then starts at the center, and proceeds first in one direction, then the other. In order to reduce distortion due to heat, it is advisable to weld a space of only 2 or 3 in. at a time. Leave a gap and weld another short length. In that way temperatures are kept down, and distortion kept to a minimum. When the weld is complete, it is hammered down, filled and finished as described in the chapter on Welding.

2.3.2. Reinstalling quarter panel

In many cases it is desirable to replace only the damaged area of a fender or panel. In general, the decision on whether to replace a panel or repair the existing panel depends on the length of time required to straighten the damaged area. Such a decision is dependent on the availability of a replacement panel, its cost, and also the cost of labor.

When only a portion of a panel is to be replaced, the first step is to straighten the area so that it is in alignment with the body. Then outline the damaged area with chalk making sure the undamaged area is not sprung out of proper contour. Take measurements carefully from the edge of the panel, the molding, or beading, and transfer these measurements to the replacement panel, scribing lines where the panel is to be cut.

Cut along these lines to obtain the desired area of the replacement panel. There are several different methods of cutting a panel, and these were described in the chapter on Cutting Sheet Metal. After straightening the cut edges of their replacement panel, position it over the damaged area. Scribe a line on the damaged panel, outlining the new replacement panels, *Figure 2- 41*. Then cut out the damaged area.

Straighten the cut edge of the damaged area, and fit the service panel portion into the cut out area in the body panel. Be sure that two parts do not overlap at any point. The new section can be held in position by C-clamps, or by vise-grip pliers, *Figure 2- 42*.

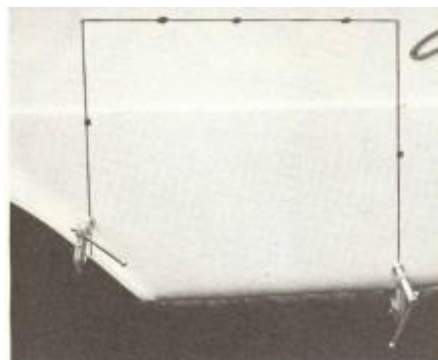

Figure 2- 43 Section of service panel is then held in position with clamps while it is welded in place.

46	Ministry of Labor and Skills Author/Copyright	Automotive Body Repair and Paint Work	Version -III
			October, 2023

2.3.3. Door panel reinstalling

If a door outer panel is severely damaged and the door inner panel is undamaged, or is in a repairable condition, a door outer panel is available for service as well as a complete door.

If the outer panel is to be replaced, first remove the door assembly and the exterior moldings' and hardware. It is not necessary to remove the window regulator, and remote control mechanisms, lock and runs.

Place the door on a flat surface with its edges extending over the edges of the surface, *Figure 2-44* Remove the hem flange by grinding, and repair any damage to the inner panel. Position the new outer repair panel, and bend the end flange over the inner flange. Spot braze the hem flange to the inner panel. Metal finish the exterior surface, paint it and assemble the interior trim and hardware.

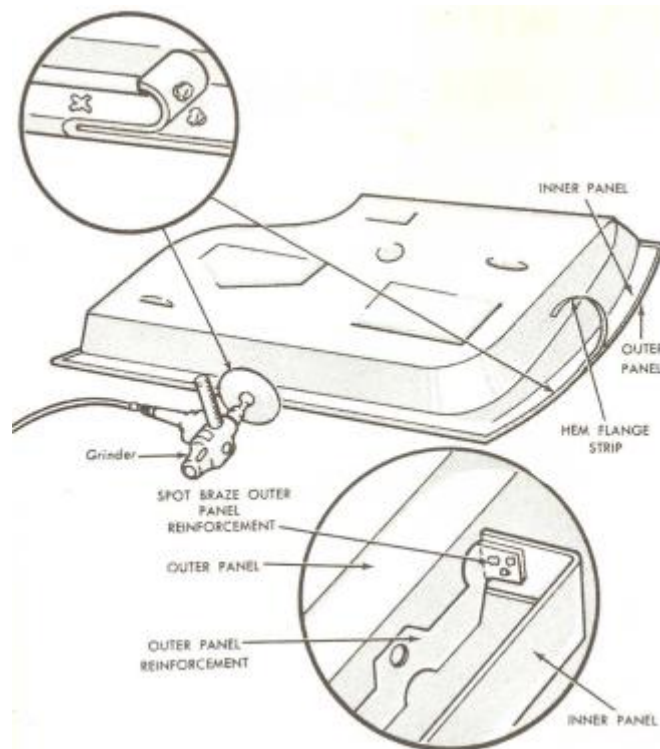

Figure 2- 45 Removing hem flange of door, prior to replacing the outer panel.

2.3.4. Top panel reinstalling

Before replacing a top it is important to have the basic body dimensions correct. These can be determined by triangular measurements as shown in Fig. 8-3. Also try the new top panel in position and use it as a template to check for any distortion of the body. After making sure the

body is in alignment and not distorted, the new top panel is carefully positioned on the car, and a line is scribed around the edge of the panel.

The old roof is then cut out with one of the methods described in a previous chapter. The new panel is again positioned on the body and is tacked in place with an occasional weld. After again checking for accurate alignment of the new panel with the body, the welding is completed. As in the case of welding other panels in position, only a few inches should be welded at a time.

After installing all new body parts, you must check overall panel alignment. Make sure that clearances between parts are equal. The gap around all parts must be within specifications. Also check that the surfaces of all panels are even with each other. Take the time to double-check all panels to ensure good alignment. This is a sign of a professional technician.

48	Ministry of Labor and Skills Author/Copyright	Automotive Body Repair and Paint Work	Version -III
			October, 2023

Self-check 2.1

Directions: Answer all the questions listed below.

Part I: Fill in the blank space

6. _____ is a rubber-tipped extension rod for holding the hood open as you remove the hood shocks and other hood parts.
7. _____ are held on a vehicle by bolts, nuts, screws, clips, and adhesives.
8. _____ is a simple tool that makes short work of shallow dents if they are not locked in by a crease in the metal.
9. _____ Spring-loaded rods used to hold the hood open when working in the engine compartment.
10. _____ is squaring the damaged body of a motor vehicle by restoring its correct shape and dimensions.

Part-II: Choose the correct answer from the given alternatives

1. Which one is from the following body and fender repair techniques

C. Analyzing Damage	C. General method
D. Repairing	D. A & B
2. _____ designed to strike sheet metal and rebound off its surface as a means of straightening minor bumps and dents. ?

E. Body hammer	
F. Hand tools	
G. Power tools	
H. A & B	
3. _____ technique to correct the alignment of the hood up and down at the rear, slightly loosen the bolts holding the hinges to the fenders or cowl. By practicing safety

A. Hood height adjustments	C. Replacing
B. Repairing	D. All
4. _____ is Stretching of the metal beyond its elastic limit takes place

A. Dent removing	C. Metal Shrinking
B. Aligning	D. All

5. The component used to allow the hood to open and close while staying in alignment?
- E. Hood hinges
 - F. Fender
 - G. Support strut
 - H. All

Part-III: Answer the following questions accordingly.

1. Discuss about how to remove the dent?
2. What are the classifications of metal shrinking methods.
3. Write about body and fender repair techniques and there functions?

Operation Sheet 2.1

Operation Title: Remove front fender

Purpose: To repair the fender

Conditions or situations for the operations:

- ✓ Safe working area
- ✓ Properly operated tools and equipment
- ✓ Appropriate working cloths fit with the body

Quality Criteria: Assured performing of all the activities according to the procedures

Precautions:

- Wearing proper clothes, eye glass
- Make working area hazard free
- Read and interpret manual which guide you how to use tools and equipment.

Steps in doing the task

Step 1. Remove front bumper as outlined in Front Bumper.

Step 2. Remove fender wheel opening molding.

Step 3. Remove wheelhouse liner as outlined in Fender Liner.

Step 4. Remove rocker panel molding as outlined in Rocker Molding

Step 5. Remove fender center molding.

Step 6. Remove nine fender bolts, Fig. 1.

Step 7. Remove fender, Fig. 1

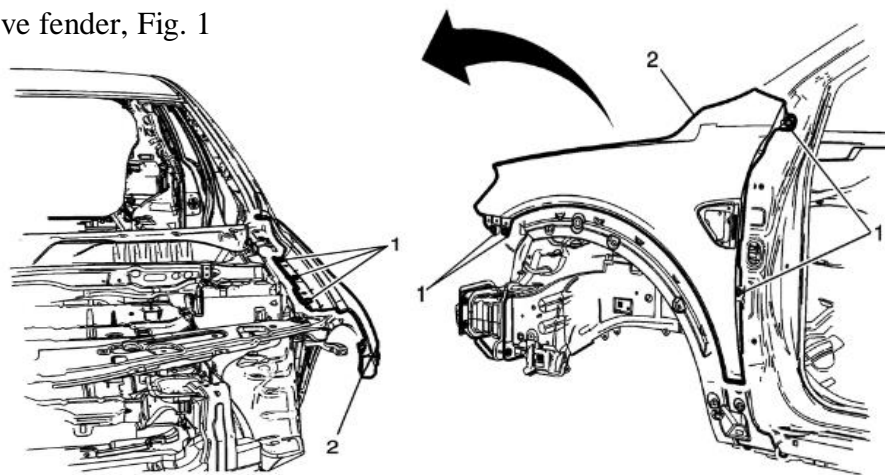

51	Ministry of Labor and Skills Author/Copyright	Automotive Body Repair and Paint Work	Version -III
			October, 2023

Operation Sheet 2.2

Operation Title: Hood removal

Purpose: To repair the Hood

Conditions or situations for the operations:

- ✓ Safe working area
- ✓ Properly operated tools and equipment
- ✓ understanding before you will carry out the actual practical exercise of door installation and removal.

Equipment Tools and Materials:

- Open ended spanner
- Ring spanner

Quality Criteria: Assured performing of all the activities according to the procedures

Precautions:

- Wearing proper clothes
- Make working area hazard free
- Read and interpret manual which guide you how to use tools and equipment.

Steps in doing the task

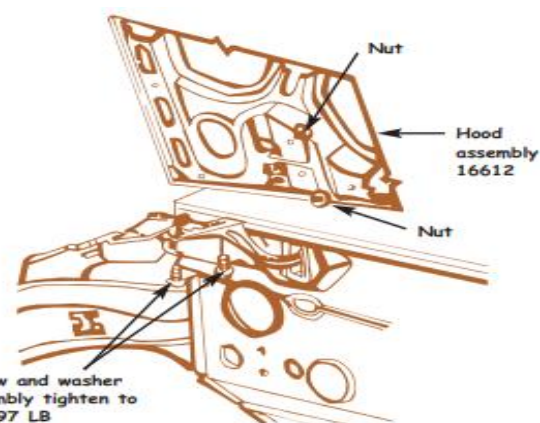
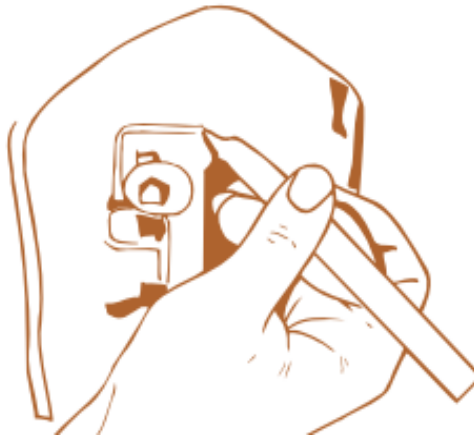
 <p>Step 1. Open the hood, Have you're assistant(s) support the weight of the hood.</p>	 <p>step 2. Match mark the hood-to-hinge position.</p>
--	--

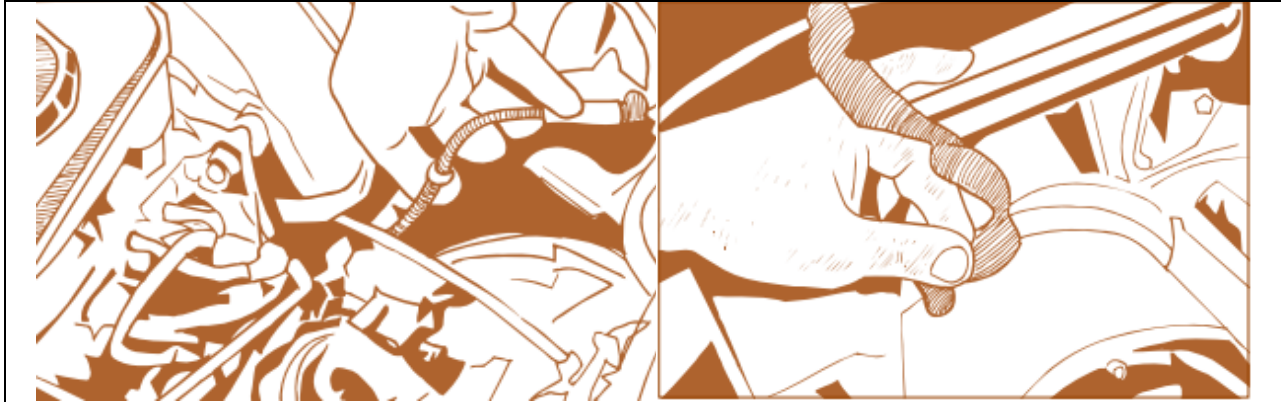

Step 3. Disconnect any electrical wire harness plugs.

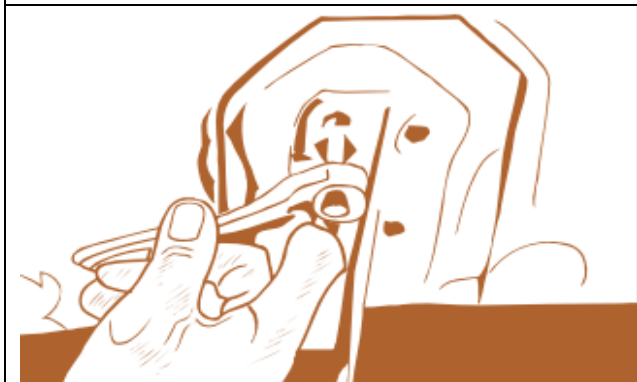

Step 4. Remove the hood-to-hinge bolts and lift the hood off of the hinges..

Step 6. Installation is the reverse of the removal. Loosely install the hood and align the match marks. Tighten the bolts securely.

Operation Sheet 2.3

Operation Title: Vehicle door

Purpose: To repair the door

Conditions or situations for the operations:

- ✓ Safe working area
- ✓ Properly operated tools and equipment
- ✓ understanding before you will carry out the actual practical exercise of door installation and removal.

Equipment Tools and Materials:

- Ratchet (typically 10mm, 12mm, 13mm)
- TORX bits (typically T25, T20, T35)
- flat screwdriver

Quality Criteria: Assured performing of all the activities according to the procedures

Precautions:

- Wearing proper clothes
- Make working area hazard free
- Read and interpret manual which guide you how to use tools and equipment.

Steps in doing the task

- Steps 1. Identify mechanism to hold door open; these can be standard or TORX bolts
- Steps 2. Determine which side is easier to remove (bolts at door or bolts at car body)
- Steps 3. Remove bolts; take care to not lose them into the door or car body
- Steps 4. Pull out rubber cover over wiring; connector may be in door or may be in car body
- Steps 5. Disconnect wiring connector (there's usually a small tab to push)
- Steps 6. Locate the bolts holding the door to the door hinges
- Steps 7. Determine which side is easier to remove (bolts at door or bolts at car body)
- Steps 8. Loosen all bolts (usually 2 per hinge)
- Steps 9. Support door while you remove all bolts (you may want to use a tire toolbox)
- Steps 10. Lift door off and ensure all wires are free so as not to damage them
- Steps 11. If you do not need the mirror or hinges, remove them and leave them for the next customer!

54	Ministry of Labor and Skills Author/Copyright	Automotive Body Repair and Paint Work	Version -III
			October, 2023

Operation Sheet 2.4

Operation Title: Remove and install vehicle trunk lid.

Purpose: To repair the trunk lid

Conditions or situations for the operations:

- ✓ Safe working area
- ✓ Properly operated tools and equipment

Equipment Tools and Materials:

- Ratchet (typically 10mm, 12mm, 13mm)
- TORX bits (typically T25, T20, T35)
- flat screwdriver

Quality Criteria: Assured performing of all the activities according to the procedures

Precautions:

- Wearing proper clothes
- Make working area hazard free
- Read and interpret manual which guide you how to use tools and equipment.

Steps in doing the task

Steps 1. Open and support the trunk lid securely

Steps 2. Mark the position of the trunk lid hinge in relation to the trunk lid.

Disconnect the trunk lid stay from its mounting bracket

Steps 3. Remove the two bolts attaching the hinge to the trunk lid.

Steps 4. Remove the trunk lid from the vehicle

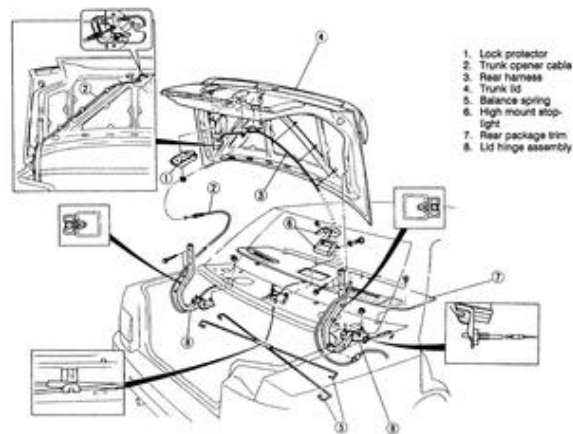

To Install

Steps 1. Align the mark on the trunk lid with the hinges

Steps 2. Install the hinge to the trunk lid bolts

Steps 3. Tighten the trunk lid bolts and adjust if necessary

55	Ministry of Labor and Skills Author/Copyright	Automotive Body Repair and Paint Work	Version -III
			October, 2023

Operation Sheet 2.5

Operation Title: Remove tailgate.

Purpose: To repair the tailgate

Conditions or situations for the operations:

- ✓ Safe working area
- ✓ Properly operated tools and equipment

Equipment Tools and Materials:

- Ratchet (typically 10mm, 12mm, 13mm)
- TORX bits (typically T25, T20, T35)
- flat screwdriver

Quality Criteria: Assured performing of all the activities according to the procedures

Precautions:

- Wearing proper clothes
- Make working area hazard free
- Read and interpret manual which guide you how to use tools and equipment.

Steps in doing the task

Steps 1. Raise the tailgate slightly, pull out and hold the cable retaining clip (A). Push the cable (C) up and off of the bolt (B). Repeat on the other side.

Steps 2. With the tailgate about halfway open, lift the right edge of the tailgate from the lower pivot. On vehicles with the tailgate assist feature, raise the tailgate nearly all the way to the closed position prior to removing the left edge.

Steps 3. Move the tailgate to the right to release the left edge.

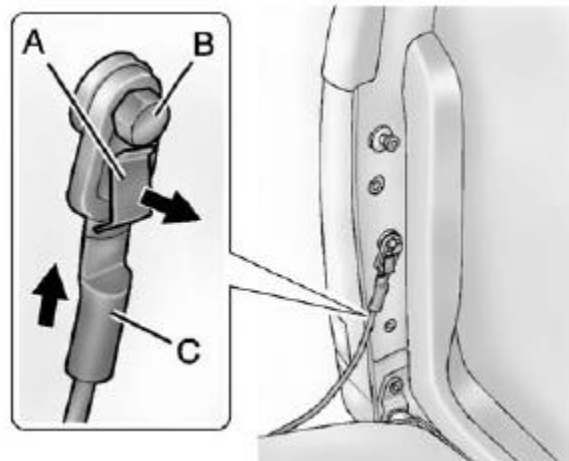

Reverse this procedure to reinstall the tailgate. Make sure the tailgate is secure.

56	Ministry of Labor and Skills Author/Copyright	Automotive Body Repair and Paint Work	Version -III
			October, 2023

Operation Sheet 2.6

Operation Title: Remove Roof

Purpose: To repair the roof

Conditions or situations for the operations:

- ✓ Safe working area
- ✓ Properly operated tools and equipment

Equipment Tools and Materials:

- Ratchet (typically 10mm, 12mm, 13mm)
- TORX bits (typically T25, T20, T35)
- flat screwdriver

Quality Criteria: Assured performing of all the activities according to the procedures

Precautions:

- Wearing proper clothes
- Make working area hazard free
- Read and interpret manual which guide you how to use tools and equipment.

Steps in doing the task

Steps 1 Using a trim removal tool, pry up on the front end of each roof molding.

Steps 2. Slide and remove the two roof moldings from the vehicle.

Steps 3. Move the tailgate to the right to release the left edge.

Steps 4. Measure and mark the roof moldings. Using an air saw, cut each roof molding as shown.

Steps 5. Reinstall the center and rear pieces of the roof molding to the roof channels.

Steps 6. Install two roof molding clips to the front pieces of the roof molding cut in step 4.

Steps 7. Reinstall the front pieces of the roof molding to the roof channels.

Operation Sheet 2.7

Operation Title: Repair dent and adjust Panel alignment

Purpose: To repair damaged panel

Conditions or situations for the operations:

- ✓ Safe working area
- ✓ Properly operated tools and equipment

Equipment Tools and Materials:

- Dollies
- Dent remover
- Straightedge

Quality Criteria: Assured performing of all the activities according to the procedures

Precautions:

- Wearing proper clothes
- Make working area hazard free
- Read and interpret manual which guide you how to use tools and equipment.

Steps in doing the task

Steps 1 A dent in a contoured part forms a crease. Proper metalworking methods are needed to remove the dent efficiently and without further stretching the metal

Steps 2. Using a properly shaped dolly, start working the dent from the ends of the crease, not from the middle. Flatten the curve at the ends of the dent so that the metal will not be stretched as the center is moved back out.

Steps 3. Next, move the center of the crease out part way. You will need the edge of a dolly with a larger contour to match the larger contour of the center area of the crease

Steps 4. Then, go back and work the ends. Try to remove the damage either as it occurred or all at once. Steps 5. Use a straightedge to check your progress.

Steps 6. Light hammer blows will help to lower any surfaces that have been raised too high. The repair area should be within 1/8 inch (3.1 mm) of level so it can be filled with body filler.

58	Ministry of Labor and Skills Author/Copyright	Automotive Body Repair and Paint Work	Version -III
			October, 2023

Procedures

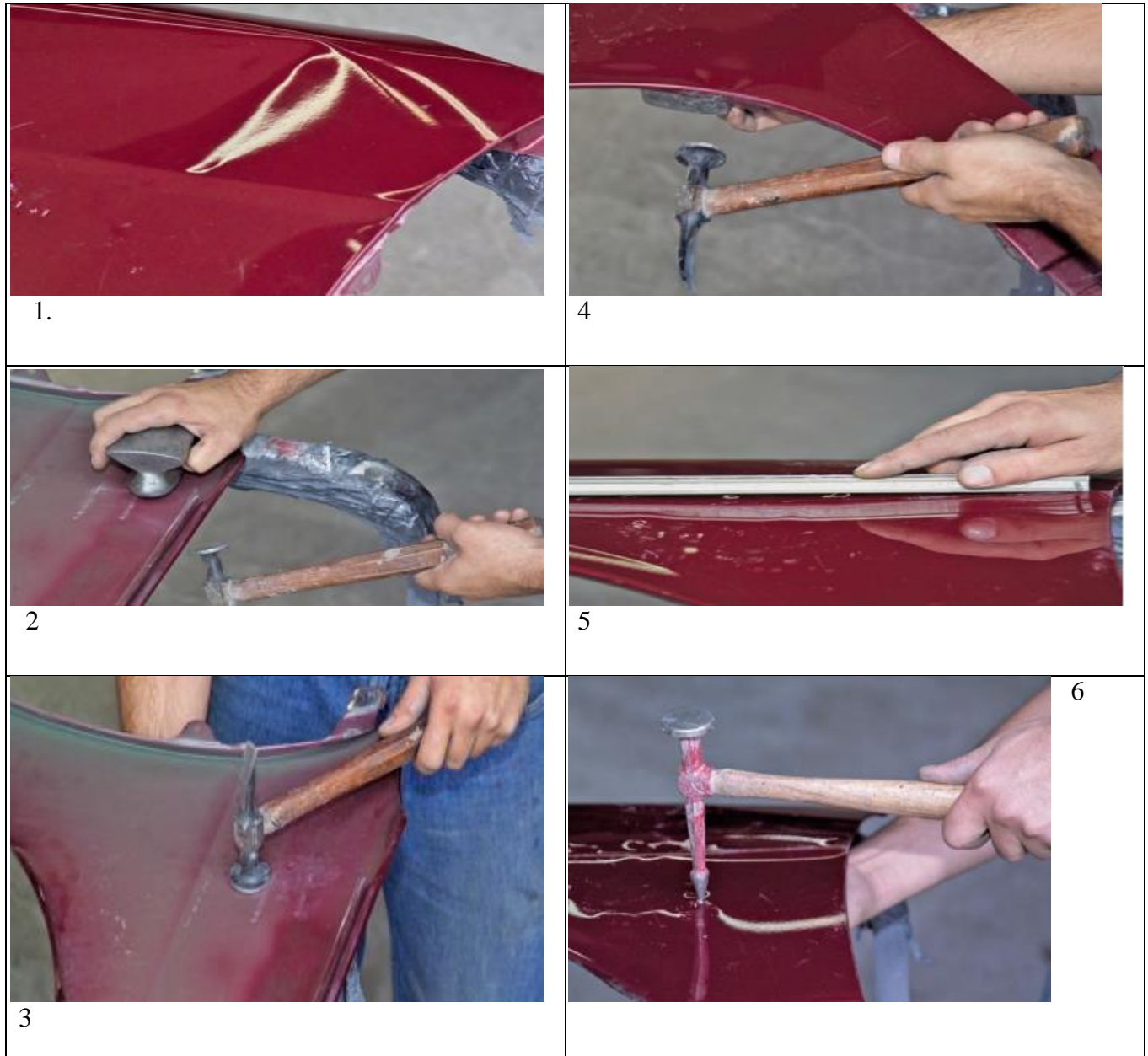

Unit Tree: - Completing and documenting Work Processes

This unit is developed to provide you the necessary information regarding the following content coverage and topics:

- Final inspection and documentation
- Check and store tools and equipment

This unit will also assist you to attain the learning outcomes stated in the cover page. Specifically, upon completion of this learning guide, you will be able to:

- Perform Final inspection and documentation
- Checking and storing tools and equipment

3.1. Final inspection and documentation

Vehicles which have been in accidents should have a Post Repair inspection to insure that the repairs were done correctly. This evaluation is performed by a qualified third-party who is tasked with examining the repairs to ensure that the proper parts were used and the proper procedures were followed. During a post repair inspection the vehicle is assessed to ensure that no safety problems exist.

Post Repair Inspections are an important component in vehicle safety. They add a second layer of protection to vehicle repairs which can save time, money and human life. As more and more insurance companies engage in Direct Repair Programs, auto body repair shops are evaluated on how quickly and inexpensively repairs can be made. Rushing through a repair or using aftermarket

parts on repairs can jeopardize a vehicle's performance and the safety of drivers and passengers.

Industry statistics have reported that over sixty percent (60%) of vehicles that were repaired have been found to have inadequate repairs that could affect the value, operation and/or safety of the vehicle and its occupants. Would it be wise to assume that the repair facility and/or the insurance company beat the odds on your vehicle's repair? Do not gamble with the safety of you and your family, know if your vehicle has remaining damage and/or was properly and thoroughly repaired.

60	Ministry of Labor and Skills Author/Copyright	Automotive Body Repair and Paint Work	Version -III
			October, 2023

Inspect Your Car’s Repaired Area Let’s say for illustration purposes that your car sustained some major front-end damage. That means not only were body panel replacements and painting required, but also repairs to the suspension, frame and engine components.

Inspect the following:

- The body panel seams for uneven gaps
- Open and close the doors, hood and trunk to notice the fit while listening for strange
- Rubbing sounds. Make sure they open easily and close securely. If an air bag was deployed was it replaced?
- Check the distance between the tires and fenders and compare those from side to
- side Ensure that all hoses and wires are connected
- Turn on your headlights and inspect the beam alignment
- If the frame needed straightening request a copy of the frame spec printout and have the before and after numbers explained to you

Vehicle inspection and delivery is the last step in the long, careful process of getting your car back to like-new condition after it has been involved in a collision.

Inspect the vehicle thoroughly post-repair to make sure that it is properly put-together and everything works as it should. Often, we'll take your vehicle for a test drive just to make sure that everything is functioning properly, there are no squeaks or rattles, and all trim pieces and body panels are properly assembled and joined.

Inspection of a repaired or replaced rear body panel

Inspect a repaired or replaced rear body panel for these conditions: dimensional alignment

- Weld quality
- Proper finish appearance and film thickness
- Proper application of corrosion protection
- Proper alignment and operation of the deck lid or hatch
- Proper alignment and operation of the rear lamps
- Proper installation of all required labels
- Correct routing of any wiring harnesses or operating cables
- Correct position and sealing of any weather strips
- Correct any defect

Store the tools

61	Ministry of Labor and Skills	Automotive Body Repair and	Version -III
	Author/Copyright	Paint Work	October, 2023

The equipment and facilities listed below are for general guidance and are not meant to be exhaustive. The workshop-in-charge shall provide all necessary equipment and facilities in accordance with relevant legislations and guidelines. The tool lists are organized into three basic categories:

- A. Hand Tools
- B. General Lab/Shop Equipment
- C. Specialty Tools and Equipment.

Good shop housekeeping

It is very important that the work area be kept clean and safe. This should be a team effort of all shop employees. Here are some simple good housekeeping precautions that should be followed in every shop.

Remember; a clean, well-organized shop is much safer to work in than a dirty, unorganized shop.

All work areas and surfaces should be kept clean, dry, and orderly. Any oil, coolant, or grease on the floor can cause slips or falls that could result in serious injuries. Items stacked on benches and tables can easily fall, and they generally cause a cluttered work area, which invites accidents. Hang tools up or put them away in your toolbox when not in use. Roll up air hoses when not in use so they do not create traffic hazards. Floor jacks, bumper jacks, jack stands, and creepers should be kept in their designated area, out of aisles and walkways.

To clean up an oil spill on the shop floor, use commercial oil absorbent. Spread the absorbent on the spill. Rub it with your foot in a circular motion. Then use a dust pan and broom to pick up the absorbent right away, especially if the spill was a flammable liquid.

Trash and rubbish should be removed from the shop area regularly. If not, serious fire dangers can result.

Clean up broken glass and remove parts with jagged metal edges from the shop area right away. Recycle bins should be provided for recycling metal and glass. If you fail to clean up broken glass properly, someone could be cut and injured. Also, if you fail to clean out dash ducts, glass can blow into people's eyes when the heater or air conditioning is turned on. Wear gloves and a full face shield.

Make sure that aisles and walkways are kept clean and are wide enough for safe clearance. Organize your work space so there is room to walk around all machines and equipment. Cluttered walking areas are a common source of injuries.

Keep all shop floor drain covers snugly in place. Open drains have caused many toe, ankle, and leg injuries.

Make sure that hazardous materials are not discharged through floor drains or other outlets leading to public waterways.

Keep gas cylinders away from sources of heat, such as a furnace or room heater. Check and service furnaces and water heaters in the shop at least once every six months.

Before leaving the shop, store toxic materials properly! Solvents, chemicals, and other materials can contaminate clothing and wind up on the hands when you remove personal protective equipment or put away the refinishing tools. Wash your hands thoroughly before handling food.

3.2. Checking and storing tools and equipment

Clean Your Tools

The best way to store your tools is to clean them after each use. If you don't maintain your tools, they will accumulate dust, dirt, and grease. Also, they won't be as effective when you need to use them the next time.

Ensure that your tools are free of grease and oil before storing them. It helps maintain their condition and prolong their lifespan.

Inspect Your Tools

No matter what trade or hobby you engage in, there's one essential rule that you should never forget: inspect your tools after every use. It is especially essential for industrial crank handles, as even a tiny nick or dent can lead to disaster.

After each use, do a quick visual inspection – it doesn't take very long. Maintaining your tools to prevent damage requires a minute or two.

- Check blades, socket sizes, and other pointed parts for any nicks or dents. If you find any damage, sharpen the damaged parts. Also, sharpen your tools at least every six months.
- Check for loose nuts or bolts and fix them immediately to prevent further damage.
- Try removing every sign of rust and corrosion, or replace the tool before use.

- Inspect power tools for cracks on their handles and housing.
- Examine the cords and plugs for any signs of damage. A damaged power cord can increase the risk of a fire hazard, so replace it with a safe power cord before using it.
- Check the user manual to follow other maintenance guidelines for your pipeline or lineman tools.

Monitor Your Environment

A dry, clean, organized space is the best environment to keep your work tools. This environment helps you find what you need when you need it, preserve your tools, and keep your work area looking professional.

Never store your tools in a hot or humid place, especially metal ones. Damp environments can corrode metals, and moist areas can degrade electrical components.

Meanwhile, a dry and cool place with low humidity helps maintain your tools for a long time. Keeping your tools in damp and stuffy garages or basements is not ideal. It can corrode metals, but other issues are also related to dampness.



Figure 3- 1 Always make your walk way clear

We recommend investing in a dehumidifier. Dehumidifiers are generally affordable and won't dent your budget when considering your tools' cost.

Practice Safety Precautions

Some of these tools can be dangerous to you and your coworkers. It would be best if you observed the following hand tool safety precautions:

- Use proper safety gear for power tools, including goggles, gloves, and a hard hat.
- Make sure the tools are in perfect condition and have been well-maintained.
- Read the instructions carefully before using the tools.
- Keep bystanders, children, and pets away from the work area.

64	Ministry of Labor and Skills Author/Copyright	Automotive Body Repair and Paint Work	Version -III
			October, 2023

- Use caution when using lineman tools near electricity.

There are many reasons to maintain your tools, the most important of which is increased efficiency. For your tools to run smoothly and last longer, maintain them properly using the tips mentioned above to clean, lubricate, inspect, and store them.

Collecting and storing material that can be reused

The proper care and storage of materials, tools and equipments are not only the concern of the management but of the workers who use the equipment.

A major responsibility of the technician is to ensure that materials, tools and equipment are maintained in a good condition and are readily available when required for the various work activities.

Faulty tools and equipments are a common reason for delays on technical activities.

Good organization of stored materials is essential for overcoming material storage problems whether on a temporary or permanent basis. There will also be fewer strain injuries if the amount of handling is reduced, especially if less manual materials handling is required. The location of the stockpiles should not interfere with work but they should still be readily available when required. Stored materials should allow at least one meter (or about three feet) of clear space under sprinkler heads.



Figure 3- 2 properly stored tools, materials and equipments

65	Ministry of Labor and Skills Author/Copyright	Automotive Body Repair and Paint Work	Version -III
			October, 2023

Self-check 3.1

Directions: Answer all the questions listed below.

Part-II: Choose the correct answer from the given alternatives

1. The best way to store your tools is to clean them after each use.
A. True B. False
2. _____ helps you find what you need when you need it, preserve your tools, and keep your work area looking professional?
A. Monitor Your Environment
B. Cleaning
C. Storing
D. A & B

Part-III: Answer the following questions accordingly.

1. Write the importance of work area be kept clean and safe?
2. Write about the purposes of inspect your tools after every use?
3. How can monitor your environment?
4. What are hand tool safety precautions?

LAP Test

Practical Demonstration

Name: _____

Date: _____

Time started: _____

Time finished: _____

Instruction: Perform the following tasks

Task 1: Removing Body panel from the vehicle

Task 2: Align body panels and components

Task 3: Reinstall body panels

67	Ministry of Labor and Skills Author/Copyright	Automotive Body Repair and Paint Work	Version -III
			October, 2023

Reference

1. Auto body repairing and repainting, bill toboldt , south holland, illinois the goodheart-willcox company, inc. publishers
2. Auto body repair technology, fifth edition, james e. duffy, in 2009 delmar cengage learning
3. Metal body repair , us army repair shop technician warrant officer advanced
4. Automotive Engineering Powertrain, Chassis System and Vehicle Body Edited by David A. Crolla, Copyright 2009 Elsevier Inc.

Cites

<https://books.google.com.et/books?id=d6lvawaaqbaj&printsec=frontcover#v=onepage&q&f=false>

<https://www.wikihow.com/remove-a-door-panel-from-a-car>

<https://www.2carpros.com/articles/door-panel-removal>

<https://carfromjapan.com/article/car-maintenance/how-to-remove-door-panel/>

<https://www.gmpartscenter.net/blog/gm-tailgate-removal-and-repair>

<file:///c:/users/user/downloads/front%20fender%20replacement.pdf>

https://www.heqmanual.com/trunk_lid_back_panel_repair_procedures-989.html

68	Ministry of Labor and Skills Author/Copyright	Automotive Body Repair and Paint Work	Version -III
			October, 2023

Developer's Profile

No	Name	Qualification (Level)	Field of Study	Organization/ Institution	Mobile number	E-mail
1	Andinet Asnake	MSc	Automotive technology	Wolkite PTC	0913767250	andinetasnake31@gmail.com
2	Tesfaye Bedada	MSc	Automotive technology	Hawassa PTC	0927831195	tesfaybedada51@gmail.com
3	Zinabu Solomon	MSc	industrial engineering	mulegetabuli	0960964523	zinabusolomon565@gmail.com
4	Gashaw Zewde	MSc	Automotive technology	ateletekenenesa	0910730747	gashawgashaw69@gmail.com
5	Yebeltal Getahun	MSc	Automotive technology	Arbaminch PTC	0916467687	yibemadi@gmail.com
6	Tilahun F/silase	BSc	Automotive technology	w/sihene PTC	0914604592	mailto:tilahunfikre@gmail.com

